

DATA SHEET, SERVICE & OPERATING MANUAL



Model M02 Metallic Design Level 1

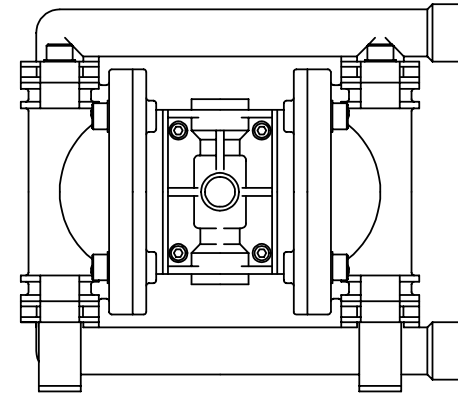
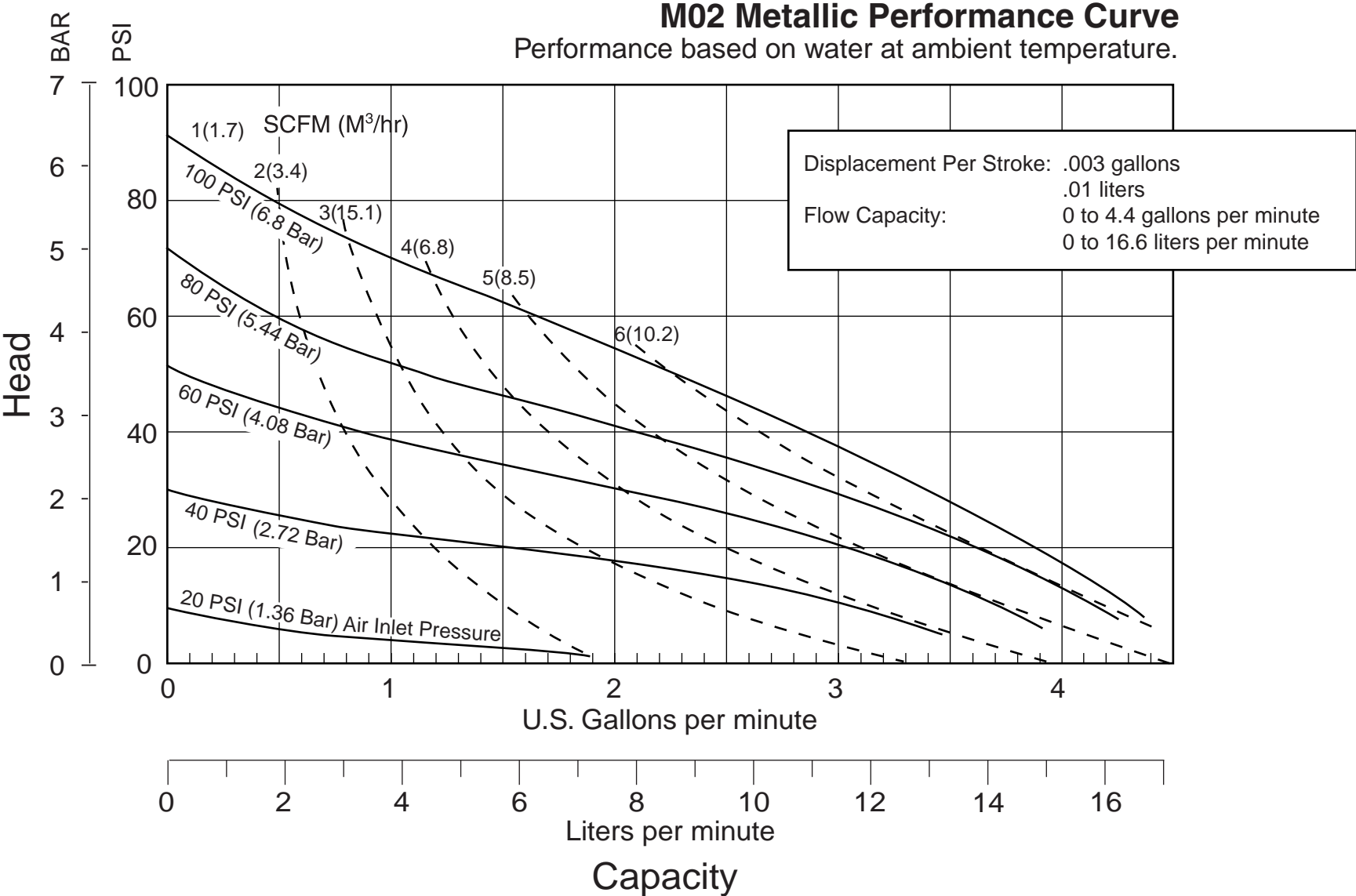

Table of Contents

Performance Curve, Model M02 Design Level 1	2	Troubleshooting Guide	6
Dimensions: M02	3	Service	7
Material Codes	4	Air Valve Systems	7
Technical Data	4	Wet-Side Overhaul, Replacing Ball Valves	7
Installation Guide	5	Wet-Side Overhaul, Replacing Diaphragms	7
Safety	6	Composite Drawing	8
Warning	6	Composite Repair Parts List	9
Flush the Pump	6		

Performance Curve, Model M02 Metallic, Design Level 1



Dimensions: M02

Dimensions in inches (metric)

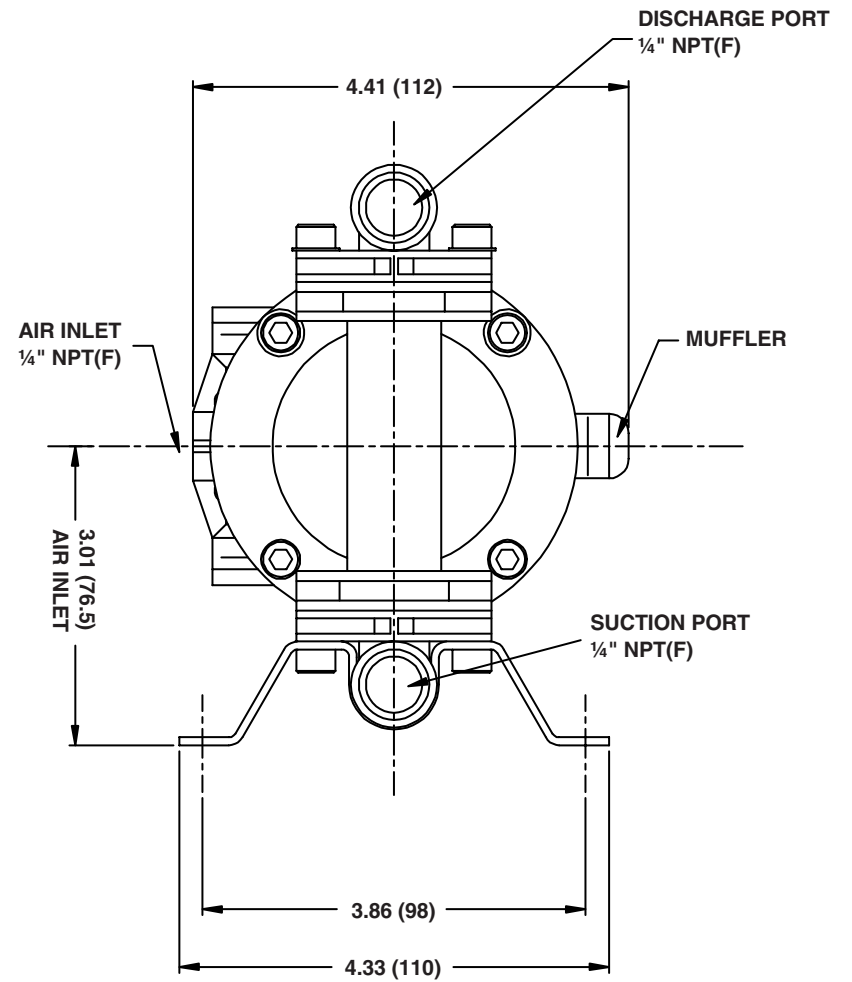
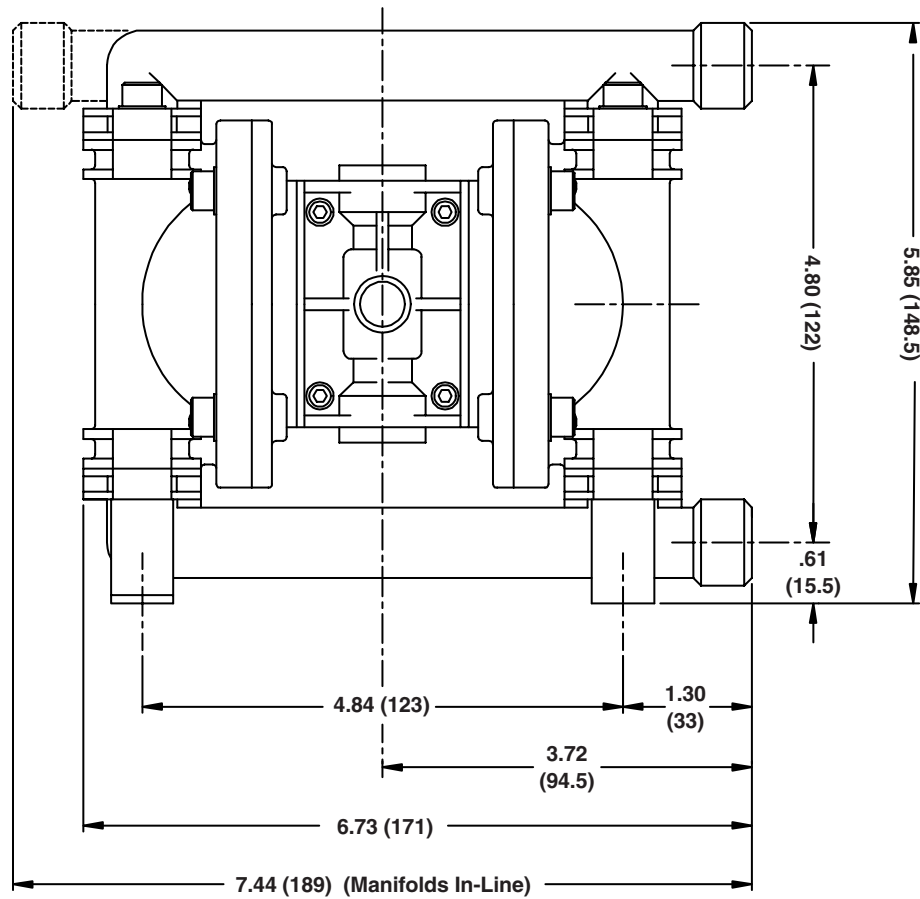

Material Codes

M02 METAL PUMP MODEL & TYPE DESIGNATIONS

X	XX	X	X	X	X	X
PUMP BRAND	PUMP SIZE	CHECK VALVE	DESIGN LEVEL	WETTED MATERIAL	DIAPHRAGM / CHECK VALVE MATERIAL	
M= Marathon	02= 1/4"	B= Ball	1- Design Level	S= Stainless Steel	Y= PTFE-Polyester Backup / PTFE Z= PTFE-Polyester Backup / Stainless Steel	
					S= Stainless Steel	

X	X	X	X	XX.
NON-WETTED MATERIAL	PORTING	PUMP STYLE	PUMP OPTIONS	KIT OPTIONS
S= Stainless Steel	N= NPT Threads	S= Standard	0= None	00.= None

TECHNICAL DATA

Max. Working Pressure: 8.6 bar (125 psi)

Max. Solid Particle Size: .08 (2mm)

Temperature Limits: Determined by Elastomers

Air Inlet: 1/4" NPT(F)

Pump Suction/
Discharge Ports: 1/4" NPT(F)

Pump Weight: 8.82 lbs. (4.0 Kg)

Installation Instructions - Typical

The typical installation shown in Figure.1 is only a guide to selecting and installing system components. Your installation will depend on the type of fluid being pumped and your application needs. To reduce the risk of serious bodily injury and damage to property, never use fluids in this pump which are not compatible with the wetted components. Contact your local distributor or the manufacturer for system design assistance & compatibility if necessary.

Mount the pump in an upright position. Failure to ensure an upright position may result in loss of or poor priming characteristics. Ensure the pump is securely mounted to avoid movement and possible risk of bodily injury.

NOTE: *Pressure Regulator (H) should be installed where air supply could exceed 8.6 Bar (125 psi).*

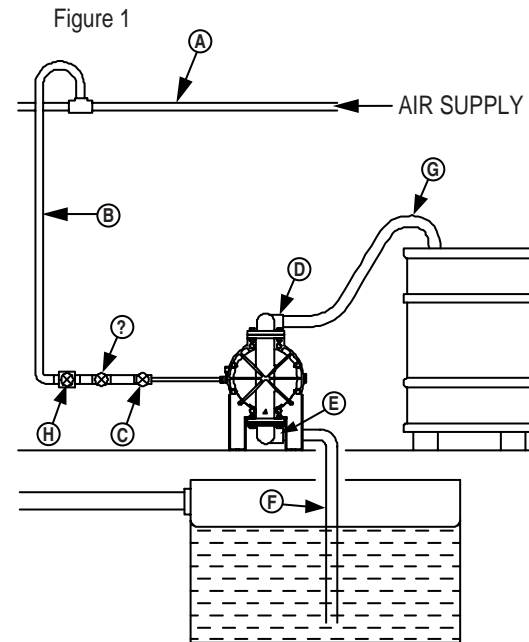
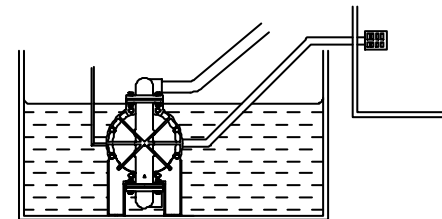

Figure 2

VENTING EXHAUST AIR



Key	
A - Main Air Line	E - Suction Port
B - Branch Air Line	F - Suction Hose - c/w Foot-valve & Strainer
C - Bleed Type Master Air Valve	G - Delivery Hose
D - Discharge Port	H - Filter/Regulator/ Lubricator

SAFETY

Your Marathon Pump M02 Model is a high performance unit capable of achieving high outputs at high efficiencies. However, as is common with pneumatic equipment, the pump efficiencies is reliant upon the air being clean, dry and filtered. Failure to comply with these requirements may lead to loss of performance and reduced component life and in extreme cases, permanent damage to the pump.

To avoid leaks, ensure that all fluid connections are tight. The use of PTFE thread tape correctly applied should ensure 100% leakproof connections. **Failure to ensure 100% sealability of the suction connection could adversely affect suction performance.**

If you are pumping hazardous fluids, or operating the pump in an enclosed area, it is essential that the exhaust from the pump is piped away to a safe location. When pumping hazardous fluids the above instructions must be adhered to in order to ensure safe operating procedures. (Under certain operating conditions the failure of internal components can lead to the pumped fluid being exhausted via the pump exhaust outlet). See Fig. 2.

WARNING

NEVER place your hands over or near the pump suction port. Powerful suction could cause serious bodily injury.

FLUSH THE PUMP

This pump was tested with water containing an oil-based rust inhibitor. If this solution could contaminate or react with the fluid you are pumping, flush the pump thoroughly with a solvent/detergent to clean internal components. The solvent/detergent must be compatible with the pump materials of construction. Care should be taken to flush the pump each time it is disassembled for maintenance or repair.

CAUTION

Ensure that only the recommended grade of lubricating oil is used. Marathon M02 Model Pumps require a SAE 10 lubricating oil. Other grades of oil may cause the Air Logic System to operate intermittently, thereby causing a loss of output and failure to operate.

If the pump accelerates or is running too fast due to a lack of fluid, then stop it immediately by shutting off the air supply. A dry pump will accelerate to a high speed causing wear to elastomers.

If the fluid you are pumping tends to dry up or set when it is not moving, then flush the pump as often as necessary to prevent the fluid from drying in the pump. Drain the pump thoroughly before storing. If feasible, invert pump to allow any fluid to drain from the non-return valves.

TROUBLE SHOOTING GUIDE

NOTE: Check all solutions before dismantling the pump.

PROBLEM	CAUSE	SOLUTION
Pump will not start	Air valve assembly malfunction/ seizure. Obstructed fluid line. Obstructed diaphragm chamber. Diaphragm failure causing fluid & excessive air to be expelled through the exhaust. Diaphragm seal failure. Air valve system malfunction.	Check carrier for freedom of movement. Clean, oil & replace. Clean line or increase line size. Remove obstruction. Replace diaphragm. Replace shaft seals. Check all seals in intermediate bracket.
Erratic flow	Diaphragm failure on one side. Valve ball not seating. Suction leakage. Diaphragm failure causing fluid & excessive air to be expelled through the exhaust. Diaphragm seal failure.	Replace diaphragm. Check and remove obstruction. Check and correct. Replace diaphragm. Replace shaft seals.
Pump strokes but will not discharge	Excessive suction lift. Suction line leakage. Valve ball not seating correctly or damaged. Suction line or strainer clogged. Diaphragm failure.	Shorten suction line. Check and correct. Check and remove obstruction/ replace. Clear. Replace diaphragm.
Fluid discharged from	Diaphragm failure.	Replace diaphragm.
Intermittent stroke rate	Over lubrication. Diaphragm rod seal failure. Air valve system malfunction. Valve ball not seating/partially obstructed.	Shut-down pump. Remove air connection into pump & introduce a small quantity of de-greasing agent into air valve and replace line. Run pump until clear. Replace seals. Check all seals in intermediate bracket. Clear obstruction.

SERVICE

NOTE: Before commencing any service or maintenance work on the pump, ensure that the air supply has been disconnected or isolated.

AIR VALVE SYSTEMS

PNEUMATIC TYPE

Remove the 4 screws securing the valve body to the intermediate bracket, together with any associated gaskets or seals.

Remove slide valve plate & slide valve from the valve body assembly. Clean all parts thoroughly and inspect for excessive wear, replacing where necessary.

The slide valve and valve plate contact faces should be flat and free from scratches. A light polishing on a flat surface with a fine abrasive paper will remove most scratches.

If excessive wear is suspected in the valve body bore or valve carrier, remove the end caps and withdraw the valve carrier. Check valve block plug o-rings for wear or attack & replace where required.

Clean the valve carrier & valve body bore with white spirits to remove any oil films.

NOTE: The nominal diametrical clearance between the valve carrier and the valve body bore should be 0.05 - 0.09mm. A clearance in excess of this will cause the valve system to run erratically.

Apply a light grease to the end cap o-rings when re-assembling into the valve body bore. Any damage to the o-ring may cause the valve system to malfunction.

Re-assemble the valve body assembly & re-torque in accordance to the settings shown in the parts list.

In the event of a complete air-side overhaul, the pump should be disassembled down to the center section assembly as described later in the "Wet-Side Overhaul" section.

With the valve body assembly dismantled, remove the inner covers where appropriate.

A careful note of the position of all related seals and gaskets should be made to facilitate re-assembly.

Remove diaphragm rod bushings where appropriate, and check all seals and o-rings for wear or damage. If worn, replace immediately.

NOTE: The integrity of the diaphragm rod seals is essential for the correct functioning of all pneumatically actuated valve systems.

Check the diaphragm rod for excessive wear as this will result in premature seal failure. Replace as required. Lubricate all components and re-assemble as detailed above, in reverse order. Ensure the correct position of all components detailed in all sectional assembly drawings.

WET-SIDE OVERHAUL

REPLACING BALL VALVES

Remove discharge manifold from pump assembly together with associated valve balls, seats and o-rings.

NOTE: The orientation of the valve seat relative to the valve ball should be noted as incorrect positioning may result in a performance loss.

Turn pump through 180° and remove the suction manifold. Clean and inspect the components. Check for any wear or damage and replace as required.

NOTE: Ball or valve seat wear may result in loss of performance and suction lift.

Re-assemble the valve balls/seat and ensure manifolds are adequately torqued to the settings shown in the parts list.

REPLACING DIAPHRAGMS

Remove both suction and discharge manifolds as detailed in the previous section, removing all ball valves, seats and o-rings.

Loosen and remove both outer chambers from the pump assembly. The orientation of the covers should be noted so as to facilitate re-assembly.

Holding one of the other diaphragm plates in a vice, ("soft jaws" should be fitted), or with an adjustable spanner, loosen and remove the outer diaphragm plate from the opposite end. Remove the inner diaphragm plate and bumpstop from diaphragm rod.

Carefully withdraw the diaphragm rod from the intermediate bracket and hold the free end in a vice, holding between the flats machined on the end. Loosen and remove the outer diaphragm and remove the diaphragm together with inner diaphragm plate and bumpstop.

NOTE: Care should be taken with all plastic, coated and hygienic pumps, so that the surface of the outer diaphragm plate is not damaged.

Thoroughly clean all parts and check for wear, damage, swelling, cracking, delamination and chemical attack. Replace components where required.

NOTE: Rubber diaphragms should be replaced if they are worn to such an extent that the fabric re-enforcing is evident on the surface of the diaphragm.

For pumps fitted with PTFE diaphragms, a light coating of grease should be applied to the back-up diaphragm prior to re-assembly.

Before re-assembly, it is advisable to check the condition of the diaphragm rod seal/o-rings for wear or attack. If either is evident, it is recommended that they be replaced.

Assemble the diaphragms onto the rod in a reverse sequence to their removal. Care should be taken as to the orientation of the diaphragm relative to the front and back plates. All diaphragms have "AIR SIDE" moulded onto one side. The inner diaphragm plate must be fitted adjacent to the "AIR SIDE" of the diaphragm.

WARNING

For repairs, use only genuine Marathon spare parts. Failure to do so may immediately invalidate any warranty claims.

Composite Repair Parts Drawing, Model M02 Metallic

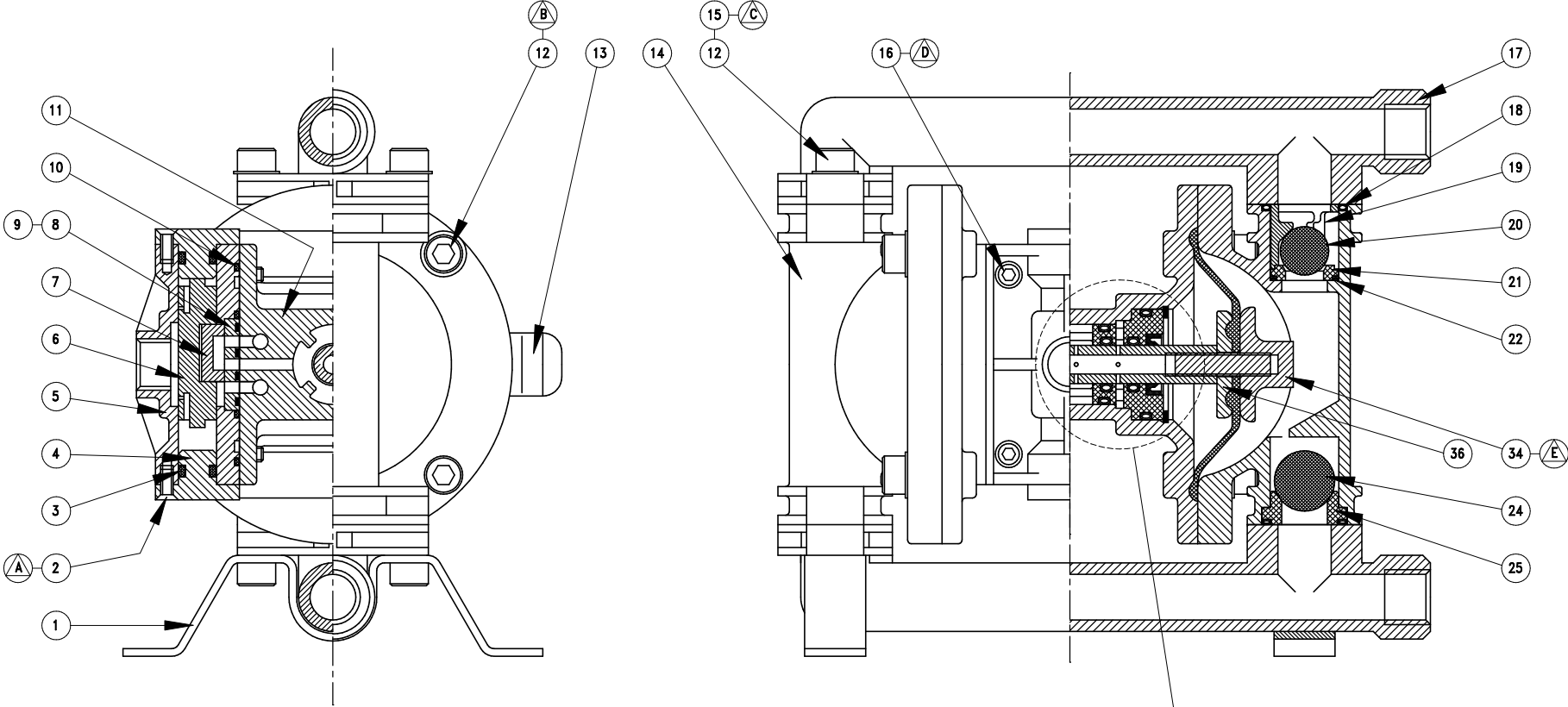

TORQUE SETTINGS	
A	3-4NM (2-3lbs/ft)
B	16NM (12lbs/ft)
C	18-20NM (13-15lbs/ft)
D	4-5NM (3-4lbs/ft)
E	10-12NM (7.5-9lbs/ft)

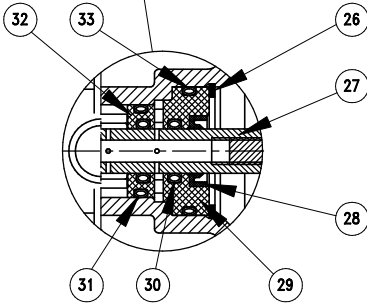
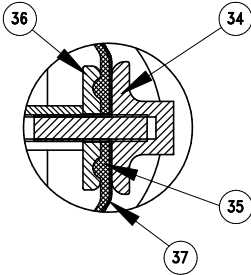

Composite Repair Parts List

ITEM	PART NO.	DESCRIPTION	QTY	ITEM	PART NO.	DESCRIPTION	QTY
1	06-140	Bracket, Mounting	2	20	06-145	Ball - Discharge, PTFE	2
2	D274	Cap Screw, Socket Countersunk (M3 x 10mm)	6		06-146	Ball - Discharge, Stainless Steel	2
3	*G258	O-Ring	2	21	06-163	Seat, Discharge Valve	2
4	06-007	Cap, End	2	22	G259	O-Ring - Valve Seat	2
5	06-068	Body, Valve	1	24	06-108	Ball - Suction, PTFE	2
6	06-005	Valve Carrier	1		06-110	Ball - Suction, Stainless Steel	2
7	06-004	Slide Valve	1	25	06-142	Seat - Suction Valve	2
8	06-003	Slide Valve Plate	1	26	H280	Ring, Retaining	2
9	*06-059	Plate Seal	1	27	06-132	Rod, Diaphragm	1
10	*06-002	Port Seal	1	28	*06-044	Seal, Diaphragm Rod	2
11	06-160	Bracket, Intermediate	1	29	06-047	Bushing, Outer	2
12	D215	Cap Screw, Socket (M6 x 20mm)	16	30	*G257	O-Ring	4
13	06-034	Muffler	1	31	*G279	O-Ring	1
14	06-139	Chamber, Outer	2	32	06-048	Bushing, Inner	2
15	C048	Washer (M6)	14	33	*G264	O-Ring	2
16	D322	Cap Screw, Socket (M4 x 10mm)	4	34	SA10160	Plate, Outer Diaphragm	2
17	06-137	Manifold	2	35	06-010	Diaphragm, Backup	2
18	G256	O-Ring - Manifold, PTFE	4	36	06-009	Inner Diaphragm Plate	2
19	06-161	Retainer	2	37	06-141	Diaphragm, Overlay	2

***Also included in item SA10440 Air End Kit**

**WARREN
RUPP®**

IDEX
IDEX CORPORATION

Declaration of Conformity ATEX 100a

In accordance with Directive 94/9/EC, Annex VIII Equipment intended for use in potentially explosive environments. Technical File No. AX1 is stored at KEMA, Notified Body 0344, under document number 203040000.

Manufacturer:

Warren Rupp, Inc.
800 North Main Street
P.O. Box 1568
Mansfield, OH 44902 USA

Applicable Standard:

94/9/EC
EN13463-1
For potentially explosive environments
Group I, Category M2
Group II, Category 2 GD



Models:

Air-Operated Double Diaphragm Metallic Pumps Series: EH, ET, G, HDB, HDF, M, MHP, MS, MP, SH, S, SA, SB, ST, T and U under SANDPIPER® and MARATHON® Brands

Metal Surge Suppressors Series: T and MSS under Tranquilizer® and MARATHON® Brands

Air-Operated Double Diaphragm Nonmetallic Conductive Acetal Pump Models: PB¼ and S05

Air-Operated Double Diaphragm Nonmetallic Conductive Polypropylene Pump Models: S05, S1F, S15, S20

SANDPIPER®
A WARREN RUPP PUMP BRAND

MARATHON®
A WARREN RUPP PUMP BRAND

DATE/APPROVAL/TITLE:

8 May 2003

Rev F 12 January 2007

David Roseberry

David Roseberry, Engineering Manager