

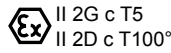

**SERVICE AND OPERATING MANUAL**



**Model SSB2-A**

USDA-Accepted Meat & Poultry Type 3

## Table of Contents

Principle of Operation.....	1
Installation and Start-Up .....	1
Air Supply .....	1
Air Inlet & Priming .....	2
Air Exhaust .....	2
Between Uses .....	2
Check Valve Servicing.....	2
Diaphragm Servicing.....	2
ESADS+Plus®: Externally Serviceable Air Distribution System .....	3
Reassembly .....	3
Pilot Valve .....	4
Pilot Valve Actuator .....	4
Service Instructions: Troubleshooting .....	4
Warranty .....	5
Recycling.....	5
Material Codes .....	6
Declaration of Conformity .....	7
Composite Repair Parts List .....	8-9
Composite Repair Drawing .....	10
Explanation of ATEX Certification.....	11

# Safety Information

## IMPORTANT



Read the safety warnings and instructions in this manual before pump installation and start-up. Failure to comply with the recommendations stated in this manual could damage the pump and void factory warranty.



When the pump is used for materials that tend to settle out or solidify, the pump should be flushed after each use to prevent damage. In freezing temperatures the pump should be completely drained between uses.

## CAUTION



Before pump operation, inspect all fasteners for loosening caused by gasket creep. Retighten loose fasteners to prevent leakage. Follow recommended torques stated in this manual.



Nonmetallic pumps and plastic components are not UV stabilized. Ultraviolet radiation can damage these parts and negatively affect material properties. Do not expose to UV light for extended periods of time.



**WARNING**  
Pump not designed, tested or certified to be powered by compressed natural gas. Powering the pump with natural gas will void the warranty.



**WARNING**  
The use of non-OEM replacement parts will void (or negate) agency certifications, including CE, ATEX, CSA, 3A and EC1935 compliance (Food Contact Materials). Warren Rupp, Inc. cannot ensure nor warrant non-OEM parts to meet the stringent requirements of the certifying agencies.

## WARNING



When used for toxic or aggressive fluids, the pump should always be flushed clean prior to disassembly.



Before maintenance or repair, shut off the compressed air line, bleed the pressure, and disconnect the air line from the pump. Be certain that approved eye protection and protective clothing are worn at all times. Failure to follow these recommendations may result in serious injury or death.



Airborne particles and loud noise hazards. Wear eye and ear protection.



In the event of diaphragm rupture, pumped material may enter the air end of the pump, and be discharged into the atmosphere. If pumping a product that is hazardous or toxic, the air exhaust must be piped to an appropriate area for safe containment.



Take action to prevent static sparking. Fire or explosion can result, especially when handling flammable liquids. The pump, piping, valves, containers and other miscellaneous equipment must be properly grounded.



This pump is pressurized internally with air pressure during operation. Make certain that all fasteners are in good condition and are reinstalled properly during reassembly.



Use safe practices when lifting

## Grounding ATEX Pumps

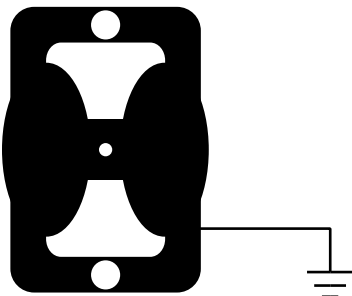

ATEX compliant pumps are suitable for use in explosive atmospheres when the equipment is properly grounded in accordance with local electrical codes. Pumps equipped with electrically conductive diaphragms are suitable for the transfer of conductive or non-conductive fluids of any explosion group. When operating pumps equipped with non-conductive diaphragms that exceed the maximum permissible projected area, as defined in EN 13463-1: 2009 section 6.7.5 table 9, the following protection methods must be applied:

- Equipment is always used to transfer electrically conductive fluids or
- Explosive environment is prevented from entering the internal portions of the pump, i.e. dry running

For further guidance on ATEX applications, please consult the factory.

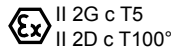

**Model SSB2-A**

USDA-Accepted Meat & Poultry Type 3

## PRINCIPLE OF OPERATION

This ball check valve pump is powered by compressed air and is a 1:1 pressure ratio design. It alternately pressurizes the inner side of one diaphragm chamber, while simultaneously exhausting the other inner chamber. This causes the diaphragms, which are connected by a common rod, to move endwise. Air pressure is applied over the entire surface of the diaphragm, while liquid is discharged from the opposite side. The diaphragm operates under a balanced condition during the discharge stroke, which allows the unit to be operated at discharge heads over 200 feet (61 meters) of water head.

Since the diaphragms are connected by a common rod, secured by plates to the center of the diaphragms, one diaphragm performs the discharge stroke, while the other is pulled to perform the suction stroke in the opposite chamber.

For maximum diaphragm life, keep the pump as close to the liquid being pumped as possible. Positive suction head in excess of 10 feet of liquid (3.048 meters) may require a back pressure regulating device. This will maximize diaphragm life.

Alternate pressuring and exhausting of the diaphragm chamber is performed by means of an externally mounted, pilot operated, four-way spool type air distribution valve. When the spool shifts to one end of the valve body, inlet air pressure is applied to one diaphragm chamber and the other diaphragm chamber exhausts. When the spool shifts to the opposite end of the valve body, the porting of chambers is reversed. The air distribution valve spool is moved by an internal pilot valve which alternately pressurizes one side of the air distribution valve spool, while exhausting the other side. The pilot valve is shifted at each end of the diaphragm stroke by the diaphragm plate coming in contact with the end of the pilot valve spool. This pushes it into position for shifting of the air distribution valve.

The chambers are manifolded together with a suction and discharge check valve for each chamber, maintaining flow in one direction through the pump.

## INSTALLATION & START-UP

Locate the pump as close to the product being pumped as possible, keeping suction line length and number of fittings to a minimum. Do not reduce line size.

For installations of rigid piping, short flexible sections of hose should be installed between pump and piping. This reduces vibration and strain to the piping system. A Warren Rupp Tranquilizer® surge suppressor is recommended to further reduce pulsation in flow.

This pump was tested at the factory prior to shipment and is ready for operation. It is completely self-priming from a dry start for suction lifts of 20 feet (6.096 meters) or less. For suction lifts exceeding 20 feet of liquid, fill the chambers with liquid prior to priming.

## AIR SUPPLY

Air supply pressures cannot exceed 125 psi (8.61 bar). Connect the pump air inlet to an air supply of sufficient capacity and pressure required for desired performance. When the air line is solid piping, use a short length of flexible hose (not less than 3/4" [19mm] in diameter) between pump and piping to eliminate strain to pipes. Use of a Warren Rupp Filter/Regulator in the air line is recommended.

## **AIR INLET & PRIMING**

For start-up, open an air valve approximately 1/2 to 3/4 turn. After the unit primes, an air valve can be opened to increase flow as desired. If opening the valve increases cycling rate, but does not increase flow rate, cavitation has occurred, and the valve should be closed slightly.

For the most efficient use of compressed air and the longest diaphragm life, throttle the air inlet to the lowest cycling rate that does not reduce flow.

## **AIR EXHAUST**

If a diaphragm fails, the pumped liquid or fumes can enter the air end of the pump, and be exhausted into the atmosphere. When pumping hazardous or toxic materials, pipe the exhaust to an appropriate area for safe disposition.

This pump can be submerged if materials of construction are compatible with the liquid. The air exhaust must be piped above the liquid level. Piping used for the air exhaust must not be smaller than 1" (2.54 cm). Reducing the pipe size will restrict air flow and reduce pump performance. When the product source is at a higher level than the pump (flooded suction), pipe the exhaust higher than the product source to prevent siphoning spills.

Freezing or icing of the air exhaust can occur under certain temperature and humidity conditions. Use of a Warren Rupp Air Dryer should eliminate most icing problems.

## **BETWEEN USES**

When used for materials that tend to settle out or transform to solid form, the pump should be completely flushed after each use, to prevent damage. Product remaining in the pump between uses could dry out or settle out. This could cause problems with valves and diaphragms at re-start. In freezing temperatures, the pump must be drained between uses in all cases.

## **CHECK VALVE SERVICING**

Need for inspection or service is usually indicated by poor priming, unstable cycling, reduced performance or the pump's cycling but not pumping.

Inspect the surfaces of both check valve and seat for wear or damage that could prevent proper sealing. If pump is to prime properly, valves must seat air tight.

## **DIAPHRAGM SERVICING**

Remove the stud nuts (six each side) securing the elbows to the outer chambers. Remove the eight knobs securing the outer chamber to the inner chamber. Remove the diaphragm assembly (outer plate, diaphragm, inner plate) by turning the assembly counterclockwise using a 15/16 (2.38 cm) wrench on the outer plate lugs. To disassemble the diaphragm assemblies, screw into the inner plates two threaded pins, place the pins in a vise and turn the outer plate counterclockwise using the 15/16 wrench. The interior components consisting of U-cup seals and sleeve bearings are now accessible for service.

Procedures for reassembling the diaphragms are the reverse of the above. The diaphragms must be installed with their natural bulge to the outside, toward the outer diaphragm plate. Install the inner plate with the flat face against the diaphragm.

After all components are in position in a vise and hand tight, tighten with a wrench to approximately 40 ft. lbs. (54.23 Newton meters) torque. After both diaphragm assemblies have been assembled, thread one assembly into the shaft (hold the shaft near the middle in a vise with soft jaws, to protect the finish). Install this subassembly into the pump and secure by placing the outer chamber on the end with the diaphragm. This holds the assembly in place while the opposite side is installed. Torque the last diaphragm assembly to 30 ft. lbs. (40.67 Newton meters). This final torquing will lock the diaphragm assemblies together. Place the remaining outer chamber on the open end and loosely tighten the bolts. Replace the manifold assemblies to square the flanges before final tightening of the remaining bolts. Alternating for progressive tightening, the eight knobs that secure outer chamber to inner chamber.

## **A NOTE ABOUT AIR VALVE LUBRICATION**

The SANDPIPER pump's pilot valve and main air valve assemblies are designed to operate WITHOUT lubrication. This is the preferred mode of operation. There may be instances of personal preference, or poor quality air supplies when lubrication of the compressed air supply is required. The pump air system will operate with properly lubricated compressed air supplies. Proper lubrication of the compressed air supply would entail the use of an air line lubricator (available from Warren Rupp) set to deliver one drop of 10 wt., non-detergent oil for every 20 SCFM of air the pump consumed at its point of operation. Consult the pump's published Performance Curve to determine this.

It is important to remember to inspect the sleeve and spool set routinely. It should move back and forth freely. This is most important when the air supply is lubricated. If a lubricator is used, oil accumulation will, over time, collect any debris from the compressed air. This can prevent the pump from operating properly.

Water in the compressed air supply can create problems such as icing or freezing of the exhaust air causing the pump to cycle erratically, or stop operating. This can be addressed by using a point of use air dryer (available from Warren Rupp) to supplement a plant's air drying equipment. This device will remove excess water from the compressed air supply and alleviate the icing or freezing problem.

## **ESADS: EXTERNALLY SERVICEABLE AIR DISTRIBUTION SYSTEM**

Please refer to the exploded view drawing and parts list in the Service Manual supplied with your pump. If you need replacement or additional copies, contact your local Warren Rupp Distributor, or the Warren Rupp factory Literature Department at the number shown below. To receive the correct manual, you must specify the MODEL and TYPE information found on the name plate of the pump.

## **MODELS WITH 1" SUCTION/DISCHARGE OR LARGER, AND METAL CENTER SECTIONS**

The main air valve sleeve and spool set is located in the valve body mounted on the pump with four hex head capscrews. The valve body assembly is removed from the pump by removing these four hex head capscrews.

With the valve body assembly off the pump, access to the sleeve and spool set is made by removing four hex head capscrews (each end) on the end caps of the valve body assembly. With the end caps removed, slide the spool back and forth in the sleeve. The spool is closely sized to the sleeve and must move freely to allow for proper pump operation. An accumulation of oil, dirt or other contaminants from the pump's air supply, or from a failed diaphragm, may prevent the spool from moving freely. This can cause the spool to stick in a position that prevents the pump from operating. If this is the case, the sleeve and spool set should be removed from the valve body for cleaning and further inspection.

Remove the spool from the sleeve. Using an arbor press or bench vise (with an improvised mandrel), press the sleeve from the valve body. Take care not to damage the sleeve. At this point, inspect the o-rings on the sleeve for nicks, tears or abrasions. Damage of this sort could happen during assembly or servicing. A sheared or cut o-ring can allow the pump's compressed air supply to leak or bypass within the air valve assembly, causing the pump to leak compressed air from the pump air exhaust or not cycle properly. This is most noticeable at pump dead head or high discharge pressure conditions. Replace any of these o-rings as required or set up a routine, preventive maintenance schedule to do so on a regular basis. This practice should include cleaning the spool and sleeve components with a safety solvent or equivalent, inspecting for signs of wear or damage, and replacing worn components.

To re-install the sleeve and spool set, lightly lubricate the o-rings on the sleeve with an o-ring assembly lubricant or lightweight oil (such as 10 wt. air line lubricant). Press the set into the valve body easily, without shearing the o-rings. Re-install one end cap, gasket and bumper on the valve body. Using the arbor press or bench vise that was used in disassembly, press the sleeve back into the valve body. You may have to clean the surfaces of the valve body where the end caps mount. Material may remain from the old gasket. Old material not cleaned from this area may cause

air leakage after reassembly. Take care that the bumper stays in place allowing the sleeve to press in all the way.

Re-install the spool, the opposite end cap, gasket and bumper on the valve body. After inspecting and cleaning the gasket surfaces on the valve body and intermediate, re-install the valve body on the pump using new gaskets. Tighten the four hex head capscrews evenly and in an alternating cross pattern.

## PILOT VALVE SERVICING

This assembly is reached by removing the air distribution valve body from the pump and lifting the pilot valve body out of the intermediate housing.

When reinserting an externally serviceable pilot valve, push both plungers out of the path of the pilot valve so that they and the pilot valve are not damaged.

**Service Note:** If a problem arises with the pilot valve, it is usually corrected by replacing only o-rings. Always grease the spool prior to inserting into the sleeve. If the sleeve is removed from the body, reinsertion must be from the same side it was removed from, the chambered side. Again, grease the o-rings so that it slides into the body. Make sure the retaining ring has securely been inserted around the sleeve.

## PILOT VALVE ACTUATOR SERVICING

The bushings for the pilot valve actuators are pressed into the intermediate bracket from the outside. The plunger may be removed for inspection or replacement from the inside by removing the air distribution valve body and the pilot valve body from the pump. The plungers should be visible as you look into the intermediate from the top. Depending on their position, you may find it necessary to use a fine piece of wire to pull them out.

Under rare circumstances, it may become necessary to replace the o-ring seal. The bushing can be pushed through the inner chamber by removing the outer chamber assembly to reach the bushing.

## TROUBLESHOOTING

### 1. Pump will not cycle

- A. Check to make sure the unit has enough pressure to operate and that the air inlet valve is open.
- B. Check the discharge line to insure that the discharge line is neither closed nor blocked.
- C. If the spool in the air distribution valve is not shifting, check the main spool. It must slide freely.
- D. Excessive air leakage in the pump can prevent cycling. This condition will be evident. Air leakage into the discharge line indicates a ruptured diaphragm. Air leakage from the exhaust port indicates leakage in the air distribution valve. See further service instructions.
- E. Blockage in the liquid chamber can impede movement of diaphragm.

### 2. Pump cycles but will not pump

- A. Suction side of pump pulling in air. Check the suction line for air leaks and be sure that the end of the suction line is submerged. Check flange bolting. Check valve flanges and manifold to chamber flange joints.
- B. Make certain the suction line or strainer is not plugged. Restriction at the suction is indicated by a high vacuum reading when a vacuum gauge is installed in the suction line.
- C. Check valves may not be seating properly. To check, remove the suction line and cover the suction port with your hand. If the unit does not pull a good suction (vacuum), the check valves should be inspected for proper seating.
- D. Static suction lift may be too high. Priming can be improved by elevating the suc-

tion and discharge lines higher than the check valves and pouring liquid into the unit through the suction inlet. When priming at high suction lifts or with long suction lines operate the pump at maximum cycle rate.

### **3. Low performance**

A. Capacity is reduced as the discharge pressure increases, as indicated on the performance curve. Performance capability varies with available inlet air supply. Check air pressure at the pump inlet when the pump is operating to make certain that adequate air supply is maintained.

B. Check vacuum at the pump suction. Capacity is reduced as vacuum increases. Reduced flow rate due to starved suction will be evident when cycle rate can be varied without change in capacity. This condition will be more prevalent when pumping viscous liquids. When pumping thick, heavy materials the suction line must be kept as large in diameter and as short as possible, to keep suction loss minimal.

C. Low flow rate and slow cycling rate indicate restricted flow through the discharge line. Low flow rate and fast cycling rate indicate restriction in the suction line or air leakage into suction.

D. Unstable cycling indicates improper check valve seating on one chamber. This condition is confirmed when unstable cycling repeats consistently on alternate exhausts. Cycling that is not consistently unstable may indicate partial exhaust restriction due to freezing and thawing of exhaust air. Use of an anti-freeze lubricant in an air line lubricator should solve this problem.

For additional information, see the Warren Rupp Troubleshooting Guide.

### **WARRANTY**

This pump is warranted for a period of five years against defective material and workmanship. Failure to comply with the recommendations stated in this manual voids all factory warranty.

#### **RECOMMENDED WARREN RUPP ACCESSORIES TO MAXIMIZE PUMP PERFORMANCE:**

- **Tranquilizer® Surge Suppressor: For nearly pulse-free flow.**
- **Warren Rupp Air Dryer: For clean, dry compressed air.**
- **Warren Rupp Filter/Regulator: For modular installation and service convenience.**
- **Warren Rupp Speed Control: For manual or programmable process control. (Manual adjustment or 4-20mA reception.)**

**For more detailed information on these accessories, contact your local Warren Rupp Factory-Authorized Distributor, or Warren Rupp corporate headquarters.**

## **RECYCLING**

Many components of SANDPIPER® AODD pumps are made of recyclable materials (see chart on page 7 for material specifications). We encourage pump users to recycle worn out parts and pumps whenever possible, after any hazardous pumped fluids are thoroughly flushed.

## MATERIAL CODES

### THE LAST 3 DIGITS OF PART NUMBER

000	Assembly, sub-assembly; and some purchased items	336	Zinc Plated Yellow Brass	553	Unfilled Polypropylene
010	Cast Iron	337	Silver Plated Steel	555	Polyvinyl Chloride
012	Powered Metal	340	Nickel Plated	556	Black Vinyl
015	Ductile Iron	342	Filled Nylon	558	Conductive HDPE
020	Ferritic Malleable Iron	351	Food Grade Santoprene	570	Rulon II
025	Music Wire	353	Geolast; Color: Black	580	Ryton
080	Carbon Steel, AISI B-1112	354	Injection Molded #203-40 Santoprene- Duro 40D +/-5; Color: RED	590	Valox
100	Alloy 20	355	Thermal Plastic	591	Nylatron G-S
110	Alloy Type 316 Stainless Steel	356	Hytrel	592	Nylatron NSB
111	Alloy Type 316 Stainless Steel (Electro Polished)	357	Injection Molded Polyurethane	600	PTFE (virgin material) Tetrafluorocarbon (TFE)
112	Alloy C	358	Urethane Rubber (Some Applications) (Compression Mold)	601	PTFE (Bronze and moly filled)
113	Alloy Type 316 Stainless Steel (Hand Polished)	359	Urethane Rubber	602	Filled PTFE
114	303 Stainless Steel	360	Nitrile Rubber Color coded: RED	603	Blue Gylon
115	302/304 Stainless Steel	361	Nitrile	604	PTFE
117	440-C Stainless Steel (Martensitic)	363	FKM (Fluorocarbon). Color coded: YELLOW	606	PTFE
120	416 Stainless Steel (Wrought Martensitic)	364	E.P.D.M. Rubber. Color coded: BLUE	607	Envelon
123	410 Stainless Steel (Wrought Martensitic)	365	Neoprene Rubber. Color coded: GREEN	608	Conductive PTFE
148	Hardcoat Anodized Aluminum	366	Food Grade Nitrile	610	PTFE Encapsulated Silicon
149	2024-T4 Aluminum	368	Food Grade EPDM	611	PTFE Encapsulated FKM
150	6061-T6 Aluminum	370	Butyl Rubber Color coded: BROWN	612	Neoprene/Hytrel
151	6063-T6 Aluminum	371	Philthane (Tuftane)	633	FKM/PTFE
152	2024-T4 Aluminum (2023-T351)	374	Carboxylated Nitrile	634	EPDM/PTFE
154	Almag 35 Aluminum	375	Fluorinated Nitrile	635	Neoprene/PTFE
155	356-T6 Aluminum	378	High Density Polypropylene	637	PTFE, FKM/PTFE
156	356-T6 Aluminum	379	Conductive Nitrile	638	PTFE, Hytrel/PTFE
157	Die Cast Aluminum Alloy #380	405	Cellulose Fibre	639	Nitrile/TFE
158	Aluminum Alloy SR-319	408	Cork and Neoprene	643	Santoprene®/EPDM
159	Anodized Aluminum	425	Compressed Fibre	644	Santoprene®/PTFE
162	Brass, Yellow, Screw Machine Stock	426	Blue Gard	656	Santoprene Diaphragm and Check Balls/EPDM Seats
165	Cast Bronze, 85-5-5-5	440	Vegetable Fibre	661	EPDM/Santoprene
166	Bronze, SAE 660	465	Fibre	666	FDA Nitrile Diaphragm, PTFE Overlay, Balls, and Seals
170	Bronze, Bearing Type, Oil Impregnated	500	Delrin 500	668	PTFE, FDA Santoprene/PTFE
175	Die Cast Zinc	501	Delrin 570		
180	Copper Alloy	502	Conductive Acetal, ESD-800		
305	Carbon Steel, Black Epoxy Coated	503	Conductive Acetal, Glass-Filled		
306	Carbon Steel, Black PTFE Coated	505	Acrylic Resin Plastic		
307	Aluminum, Black Epoxy Coated	506	Delrin 150		
308	Stainless Steel, Black PTFE Coated	520	Injection Molded PVDF Natural color		
309	Aluminum, Black PTFE Coated	540	Nylon		
310	PVDF Coated	541	Nylon		
313	Aluminum, White Epoxy Coated	542	Nylon		
330	Zinc Plated Steel	544	Nylon Injection Molded		
331	Chrome Plated Steel	550	Polyethylene		
332	Aluminum, Electroless Nickel Plated	551	Glass Filled Polypropylene		
333	Carbon Steel, Electroless Nickel Plated	552	Unfilled Polypropylene		
335	Galvanized Steel				

Delrin and Hytrel are registered tradenames of E.I. DuPont.

Gylon is a registered tradename of Garlock, Inc.

Nylatron is a registered tradename of Polymer Corp.

Santoprene is a registered tradename of Monsanto Corp.

Rulon II is a registered tradename of Dixon Industries Corp.

Ryton is a registered tradename of Phillips Chemical Co.

Valox is a registered tradename of General Electric Co.

PortaPump, Tranquilizer and SludgeMaster are registered tradenames of IDEX AODD, Inc.



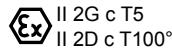

**SERVICE AND OPERATING MANUAL**

**EAC CE Model SSB2-A**

USDA-Accepted Meat & Poultry Type 3

ITEM NO.	PART NUMBER	DESCRIPTION	TOTAL RQD.
1	070-006-170	Bearing, Sleeve	2
2	<b>114-005-332</b>	<b>Bracket, Intermediate</b>	<b>1</b>
3	<b>720-004-360</b>	<b>Seal, U-Cup</b>	<b>2</b>
4	135-016-162	Bushing, Threaded	2
5	620-011-114	Plunger, Actuator	2
6	<b>095-073-000</b>	<b>Pilot Valve Body Ass'y.*</b>	<b>1</b>
6-A	<b>095-070-551</b>	<b>Pilot Valve Body</b>	<b>1</b>
6-B	<b>755-025-000</b>	<b>Sleeve (w/O-Ring)</b>	<b>1</b>
6-C	<b>560-033-360</b>	<b>O-Ring (Sleeve)</b>	<b>4</b>
6-D	<b>775-026-000</b>	<b>Spool (w/O-Ring)</b>	<b>1</b>
6-E	<b>560-023-360</b>	<b>O-Ring (Spool)</b>	<b>2</b>
6-F	<b>675-037-080</b>	<b>Retaining Ring</b>	<b>1</b>
7	<b>360-041-379</b>	<b>Gasket, Valve Body</b>	<b>1</b>
8	560-001-360	O-Ring	2
9	095-047-332	Body, Valve	1
10	<b>132-014-358</b>	<b>Bumper, Valve Spool</b>	<b>2</b>
11	165-011-332	Cap, End	2
12	<b>360-048-425</b>	<b>Gasket, Valve Body</b>	<b>1</b>
13	<b>360-010-425</b>	<b>Gasket, End Cap</b>	<b>2</b>
14	<b>560-020-360</b>	<b>O-Ring</b>	<b>6</b>
15	<b>031-012-000</b>	<b>Sleeve &amp; Spool Set</b>	<b>1</b>
16	170-032-115	Capscrew, Hex Head 1/4-20 X .75	8
17	170-045-115	Capscrew, Hex Head 5/16-18 X 1.25	4
18	<b>132-002-360</b>	<b>Bumper, Diaphragm</b>	<b>2</b>
19	196-068-332	Chamber, Inner	2
20	<b>286-005-366</b>	<b>Diaphragm</b>	<b>2</b>
	<b>286-005-351</b>	<b>Diaphragm</b>	<b>2</b>
	<b>286-114-000</b>	<b>Diaphragm, One Piece PTFE</b>	<b>2</b>
		<b>(Must use 612.219.150 Inner plates)</b>	
21	<b>560-022-360</b>	<b>O-Ring</b>	<b>2</b>
22	<b>685-007-120</b>	<b>Rod, Diaphragm</b>	<b>1</b>
23	478-007-115	Knob, Locking	16
24	170-024-115	Capscrew, Hex Head 7/16-14 X 1	8
25	618-003-110	Plug Pipe	2
26	900-006-115	Washer, Lock	16
27	612-052-157	Plate, Inner	2
	612-219-150	Plate, Inner, One Piece PTFE	2
		<b>(Only used w/ 286.114.000 diaphragms)</b>	
28	612-097-111	Plate, Outer	2
29	807-026-115	Stud	2
30	518-051-110	Manifold, Suction	1
31	518-050-110	Manifold, Discharge	1
32	<b>722-040-366</b>	<b>Seat, Valve</b>	<b>4</b>
	<b>722-040-368</b>	<b>Seat, Valve</b>	<b>4</b>
33	<b>050-017-366W</b>	<b>Ball, Check Valve</b>	<b>4</b>
	<b>050-017-368W</b>	<b>Ball, Check Valve</b>	<b>4</b>
	<b>050-017-351</b>	<b>Ball, Check Valve</b>	<b>4</b>
34	542-007-000	Stud Nut Ass'y.	8

Repair Parts shown in **bold face (darker)** type are more likely to need replacement after extended periods of normal use. The pump owner may prefer to maintain a limited inventory of these parts in his own stock to reduce repair downtime to a minimum.

**IMPORTANT:** When ordering repair parts always furnish pump model number, serial number and type number.

ITEM NO.	PART NUMBER	DESCRIPTION	TOTAL RQD.
35	560-001-360	O-Ring	2
36	902-003-000	Stat-O-Seal	2
37	200-032-115	Clamp, Discharge	2
38	200-034-115	Clamp, Suction	2
39	542-002-114	Nut, Stud	4
41	196-070-111	Chamber, Outer	2
42	530-036-000	Muffler, Exhaust	1
43	312-057-111	Elbow, Suction	2
44	312-058-111	Elbow, Discharge	2
45	361-005-366	Gasket, Sealing (Discharge)	2
	361-005-368	Gasket, Sealing (Discharge)	2
46	361-008-366	Gasket, Sealing (Suction)	2
	361-008-368	Gasket, Sealing (Suction)	2
47	031-019-332	Main Air Valve Assembly (Inc. Items 9, 10, 11, 13, 14, 15, 16)	1
48	807-056-115	Stud	8
49	545-007-115	Nut, Hex	8
50	807-032-115	Stud	8
51	115-083-115	Bracket, Foot (Left)	2
52	115-084-115	Bracket, Foot (Right)	2
53	545-007-115	Nut, 7/16 Hex	8

\* Available in kit form. Order P/N 031-055-000 which also includes Item Nos. 5, 7, 12, 35.

SPHERICAL  
END TOWARDS  
CLAMP

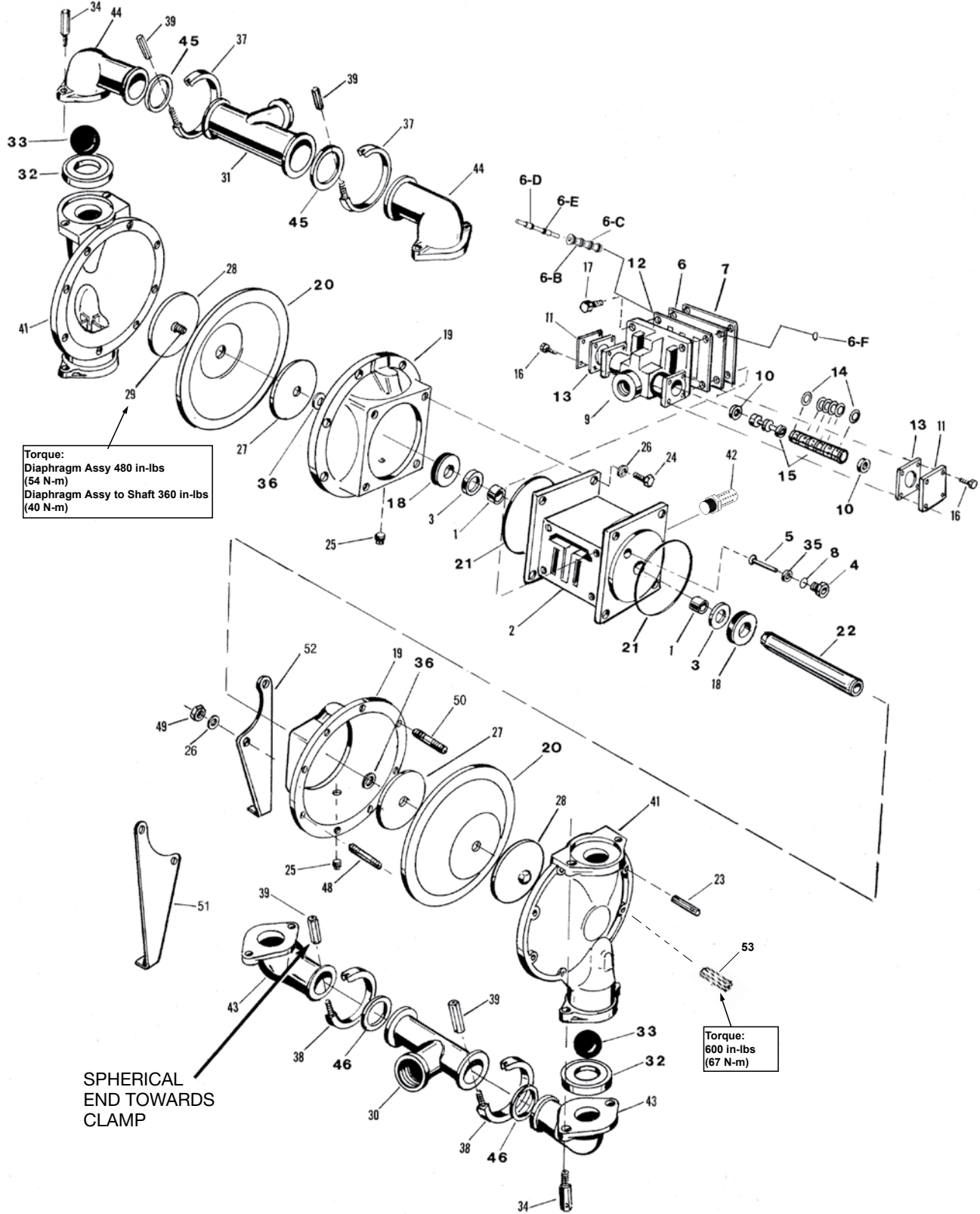

# 5 - YEAR Limited Product Warranty

Warren Rupp, Inc. ("Warren Rupp") warrants to the original end-use purchaser that no product sold by Warren Rupp that bears a Warren Rupp brand shall fail under normal use and service due to a defect in material or workmanship within five years from the date of shipment from Warren Rupp's factory. Warren Rupp brands include Warren Rupp®, SANDPIPER®, SANDPIPER Signature Series™, MARATHON®, Porta-Pump®, SludgeMaster™ and Tranquilizer®.

The use of non-OEM replacement parts will void (or negate) agency certifications, including CE, ATEX, CSA, 3A and EC1935 compliance (Food Contact Materials). Warren Rupp, Inc. cannot ensure nor warrant non-OEM parts to meet the stringent requirements of the certifying agencies.

~ See [sandpiperpump.com/content/warranty-certifications](http://sandpiperpump.com/content/warranty-certifications) for complete warranty, including terms and conditions, limitations and exclusions. ~

**WARREN  
RUPP, INC.**

## Declaration of Conformity

**Manufacturer: Warren Rupp, Inc., 800 N. Main Street  
Mansfield, Ohio, 44902 USA**

Certifies that Air-Operated Double Diaphragm Pump Series: HDB, HDF, M Non-Metallic, S Non-Metallic, M Metallic, S Metallic, T Series, G Series, U Series, EH and SH High Pressure, RS Series, W Series, SMA and SPA Submersibles, and Tranquilizer® Surge Suppressors comply with the European Community Directive 2006/42/EC on Machinery, according to Annex VIII. This product has used Harmonized Standard EN809:1998+A1:2009, Pumps and Pump Units for Liquids - Common Safety Requirements, to verify conformance.

  
Signature of authorized person

October 20, 2005  
Date of issue

Authorised Representative:  
IDEX Pump Technologies  
R79 Shannon Industrial Estate  
Shannon, Co. Clare, Ireland

Director of Engineering  
Title

February 27, 2017  
Date of revision

Attn: Barry McMahon

**IDEX**

Revision Level: F

**CE**

# **WARREN RUPP, INC.**

## **EC / EU Declaration of Conformity**

The objective of the declaration described is in conformity with the relevant Union harmonisation legislation: Directive 94/9/EC (until April 19, 2016) and Directive 2014/34/EU (from April 20, 2016).

**Manufacturer:**

Warren Rupp, Inc.  
A Unit of IDEX Corporation  
800 North Main Street  
P.O. Box 1568  
Mansfield, OH 44902 USA

**Applicable Standard:**

EN13463-1: 2001  
EN13463-5: 2003  
EN60079-25: 2004

**Harmonised Standard:**

EN13463-1: 2009  
EN13463-5: 2011  
EN60079-25:2010

The harmonised standards have been compared to the applicable standards used for certification purposes and no changes in the state of the art technical knowledge apply to the listed equipment.

**AODD Pumps and Surge Suppressors**

Technical File No.: 203104000-1410/MER

**AODD (Air-Operated Double Diaphragm) Pumps**

EC Type Examination Certificate No. Pumps: KEMA 09ATEX0071 X

DEKRA Certification B.V. (0344)  
Meander 1051  
6825 MJ Arnhem  
The Netherlands

**Hazardous Locations Applied:**

I M1 c	II 1 G c T5
II 2 G Ex ia c IIC T5	II 1 D c T100°C
II 2 D Ex c iaD 20 IP67 T100°C	II 2 G c T5
II 2 G Eex m c II T5	II 2 D c T100°C
II 2 D c IP65 T100°C	II 2 G c IIB T5

**SANDPIPER®**  
A WARREN RUPP, INC. BRAND

**Tranquilizer®**

DATE/APPROVAL/TITLE:  
18 March 2016

*David Roseberry*  
David Roseberry, Director of Engineering

**IDEX**