



# SERVICE AND OPERATING MANUAL



Original Instructions

## ET3 - M

### CONTAINMENT DUTY Type 1



## Table of Contents

Engineering Data, Temperature Limitations, & Performance Curve .....	1
Explanation of Pump Nomenclature .....	1
Dimensions .....	2
Principle of Operation .....	3
Installation and Start-Up .....	3
Air Supply .....	4
Air Inlet & Priming .....	4
ESADS+Plus®: Externally Serviceable Air Distribution System .....	4
Air Exhaust .....	5
Between Uses .....	5
Check Valve Servicing .....	6
Diaphragm Servicing .....	6
Pilot Valve .....	6
Pilot Valve Actuator .....	6
Service Instructions: Troubleshooting .....	7
Warranty .....	7
Composite Repair Parts List .....	8-9
Composite Repair Drawing .....	10
Important Safety Information .....	11
Material Codes .....	12
Declaration of Conformity - Machinery .....	13



# SANDPIPER®

A WARREN RUPP PUMP BRAND

## CONTAINMENT DUTY ET3-M Type I

### Air-Powered Double-Diaphragm Pump

ENGINEERING, PERFORMANCE  
& CONSTRUCTION DATA

Quality System  
ISO9001 Certified

Environmental  
Management System  
ISO14001 Certified



INTAKE/DISCHARGE PIPE SIZE	CAPACITY	AIR VALVE	SOLIDS-HANDLING	HEADS UP TO
3" (76mm) 150# raised face flange	0 to 260 gallons per minute (0 to 988 liters per minute)	No-lube, no-stall design.	Up to 7/16" (10 mm)	125 psi or 289 ft. of water (8.8 Kg/cm <sup>2</sup> or 88 meters)

### SANDPIPER® Containment Duty Pumps: Sealless Safety

This pump is part of the Containment Duty Pumps. It is specially fitted with elastomeric driver diaphragms, aluminum spill containment chambers, and elastomeric or PTFE pumping diaphragms. The liquid-filled containment chambers provide an additional spill containment barrier, should a pumping diaphragm fail. The Containment Duty design gives the pump user advanced warning of diaphragm failure, before pumpage can damage the air valve, or be released into the work environment. A "sight tube" style of visual leak detection is standard on this pump, displaying an obvious color change if a leak occurs in the pumping diaphragm. Electronic leak detection is optional with this model.

The Containment Duty Pumps offers many different levels of materials and spill monitoring devices designed to fit a variety of applications and budgets.

### PERFORMANCE CURVES

(SANDPIPER® pumps are designed to be powered **only** by compressed air)  
Temperature Limit: 212°F - 100°C

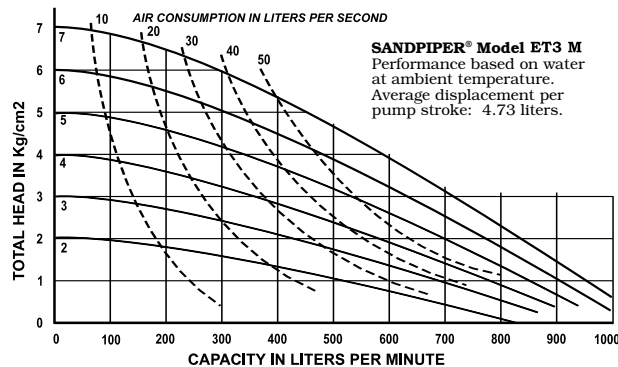
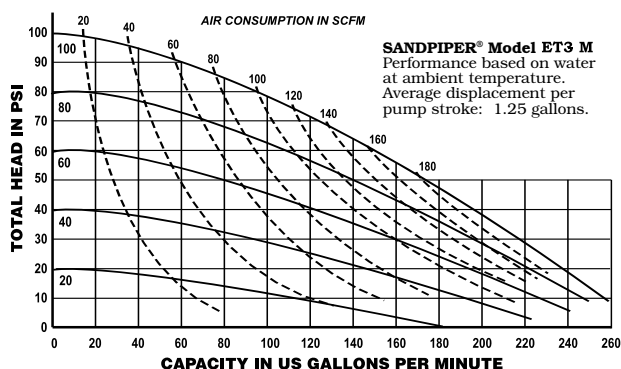

### MATERIALS OF CONSTRUCTION

ET3-M Type 1	Manifold	Outer Chamber	Inner Chamber	Driver Chamber	Outer Diaphragm Plate	Inner Diaphragm Plate	Intermediate Housing	Diaphragm Rod	Valve Seat	Hardware	Pumping Diaphragm	Driver Diaphragm	Ball Valve Material	Air Valve	Shipping Weight (lbs)
TNN-1-A	AL356T6	AL356T6	DI	AL356T6	AL356T6	CI	AL356T6	416SS	N	PS	N	N	N	AL356T6	208
THI-1-A	AL356T6	AL356T6	DI	AL356T6	AL356T6	CI	AL356T6	416SS	T	PS	E	E	T	AL356T6	208
TCV-1-A	AL356T6	AL356T6	DI	AL356T6	AL356T6	CI	AL356T6	416SS	T	PS	V	V	T	AL356T6	208
TBB-1-A	AL356T6	AL356T6	DI	AL356T6	AL356T6	CI	AL356T6	416SS	B	PS	B	B	B	AL356T6	208
TQS-1-A	AL356T6	AL356T6	DI	AL356T6	AL356T6	CI	AL356T6	416SS	N	PS	S	S	N	AL356T6	208
TGN-1-A	AL356T6	AL356T6	DI	AL356T6	AL356T6	CI	AL356T6	416SS	T	PS	T	N	T	AL356T6	208
TGN-1-SI	SS	SS	DI	SS	SS	CI	CI	416SS	T	PS	T	N	T	CI	494

#### Meanings of Abbreviations:

AL = Aluminum  
B = Buna N  
CI = Cast Iron

DI = Ductile Iron  
E = EPDM  
N = Neoprene

PS = Plated Steel  
S = Santoprene®  
SS = Stainless Steel

T = Virgin PTFE  
WR-S = Warren Rupp Alloy Type 316 Stainless Steel

Viton® is a registered trademark of E.I. du Pont. Santoprene® is a registered trademark of Monsanto Corp. SANDPIPER® and Warren Rupp are registered trademarks of Warren Rupp, Inc.

# ET3-M CONTAINMENT DUTY

MATERIALS	Operating Temperatures		
	Maximum*	Minimum*	Optimum**
<b>BUNA-N</b> General purpose, oil-resistant. Shows good solvent, oil, water and hydraulic fluid resistance. Should not be used with highly polar solvents like acetone and MEK, ozone, chlorinated hydrocarbons and nitro hydrocarbons.	190°F 88°C	-10°F -23°C	50°F to 140°F 10°C to 60°C
<b>EPDM</b> Shows very good water and chemical resistance. Has poor resistance to oil and solvents, but is fair in ketones and alcohols.	212°F+ 100°C+	-10°F -23°C	50°F to 212°F 10°C to 100°C
<b>NEOPRENE</b> All purpose. Resistant to vegetable oils. Generally not affected by moderate chemicals, fats, greases and many oils and solvents. Generally attacked by strong oxidizing acids, ketones, esters, nitro hydrocarbons and chlorinated aromatic hydrocarbons.	170°F 77°C	-35°F -37°C	50°F to 130°F 10°C to 54°C
<b>SANTOPRENE®</b> Injection molded thermoplastic elastomer with no fabric layer. Long mechanical flex life. Excellent abrasion resistance.	212°F+ 100°C+	-35°F -37°C	50°F to 212°F 10°C to 100°C
<b>PTFE</b> Chemically inert, virtually impervious. Very few chemicals are known to chemically react with PTFE: molten alkali metals, turbulent liquid or gaseous fluorine and a few fluorochemicals such as chlorine trifluoride or oxygen difluoride which readily liberate free fluorine at elevated temperatures.	212°F+ 100°C+	-10°F -23°C	50°F to 212°F 10°C to 100°C
<b>VITON®</b> Shows good resistance to a wide range of oils and solvents; especially all aliphatic, aromatic and halogenated hydrocarbons, acids, animal and vegetable oils. Hot water or hot aqueous solutions (over 70°F) will attack Viton®.	212°F+ 100°C+	+32°F 0°C	75°F to 212°F 24°C to 100°C

For specific applications, always consult the Warren Rupp Chemical Resistance Chart.

\*Definite reduction in service life.  
\*\*Minimal reduction in service life at ends of range.

Dimensions are ± 1/8"  
Figures in parenthesis = millimeters

Dimension	A
Standard Pump	7" (178)
Pulse Output Kit	7.9/16" (192)

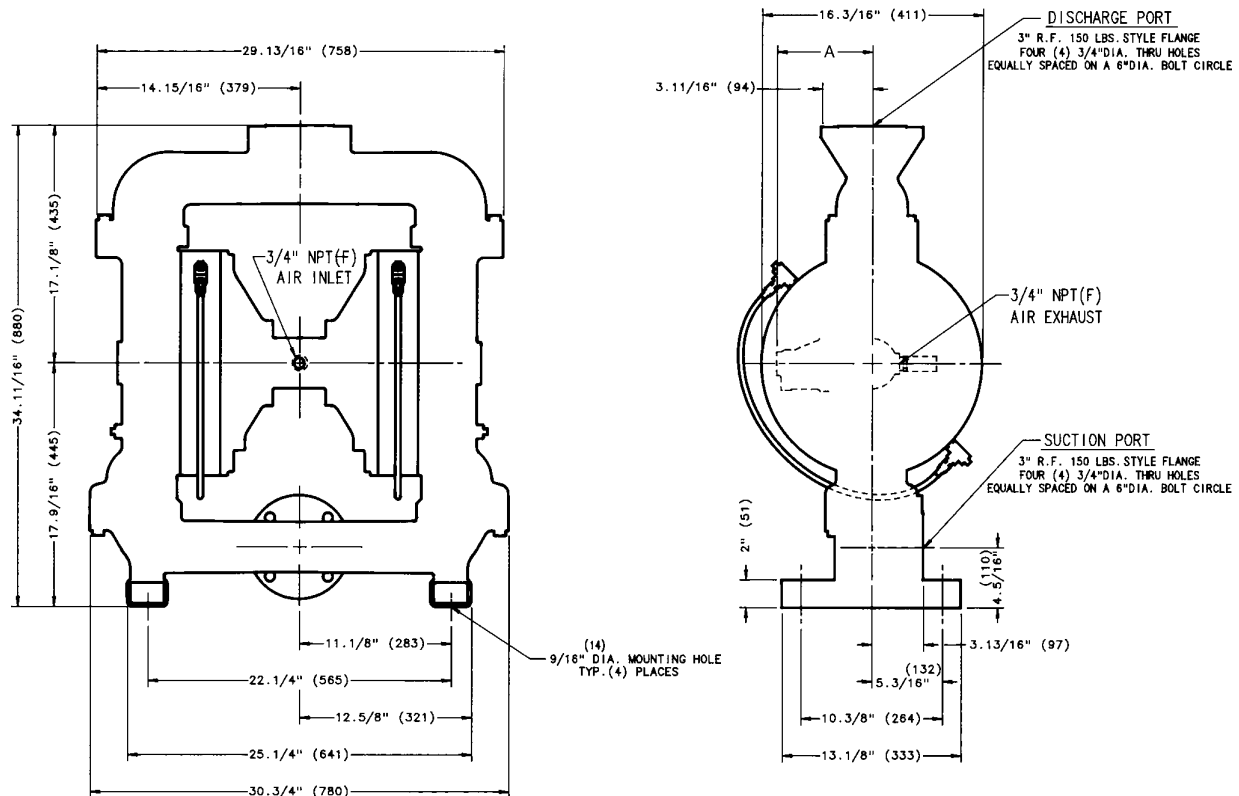

**3" ASA-STYLE FLANGED SUCTION AND DISCHARGE • 3/4" NPT(F) AIR INLET PORT • 3/4" NPT(F) AIR EXHAUST PORT**



## SERVICE AND OPERATING MANUAL



Original Instructions

**ET3 - M**

CONTAINMENT DUTY Type 1

### PRINCIPLE OF OPERATION

This ball check valve pump is powered by compressed air and is a 1:1 pressure ratio design. It alternately pressurizes the inner side of one diaphragm chamber, while simultaneously exhausting the other inner chamber. This causes the diaphragms, which are connected by a common rod, to move endwise. Air pressure is applied over the entire surface of the diaphragm, while liquid is discharged from the opposite side. The diaphragm operates under a balanced condition during the discharge stroke, which allows the unit to be operated at discharge heads over 200 feet (61 meters) of water head.

Since the diaphragms are connected by a common rod, secured by plates to the center of the diaphragms, one diaphragm performs the discharge stroke, while the other is pulled to perform the suction stroke in the opposite chamber.

For maximum diaphragm life, keep the pump as close to the liquid being pumped as possible. Positive suction head in excess of 10 feet of liquid (3.048 meters) may require a back pressure regulating device. This will maximize diaphragm life.

Alternate pressuring and exhausting of the diaphragm chamber is performed by means of an externally mounted, pilot operated, four-way spool type air distribution valve. When the spool shifts to one end of the valve body, inlet air pressure is applied to one diaphragm chamber and the other diaphragm chamber exhausts. When the spool shifts to the opposite end of the valve body, the porting of chambers is reversed. The air distribution valve spool is moved by an internal pilot valve which alternately pressurizes one side of the air distribution valve spool, while exhausting the other side. The pilot valve is shifted at each end of the diaphragm stroke by the diaphragm plate coming in contact with the end of the pilot valve spool. This pushes it into position for shifting of the air distribution valve.

The chambers are manifolded together with a suction and discharge check valve for each chamber, maintaining flow in one direction through the pump.

This SandPIPER pump differs from others in that it utilizes four diaphragms instead of two. The two rod-connected diaphragms are the driver diaphragms, and the other two (outermost) diaphragms are the actual pumping diaphragms. Each driver diaphragm (of Neoprene or other elastomer), and the pumping diaphragm (of TFE), are separated by a chamber filled with liquid which transmits the reciprocating motion of the driver diaphragm to the pumping diaphragm. The pumping diaphragms, create the alternating suction and discharge action to each outer diaphragm chamber. The pumping diaphragms are the only ones in contact with the liquid being pumped.

### INSTALLATION & START-UP

Locate the pump as close to the product being pumped as possible, keeping suction line length and number of fittings to a minimum. Do not reduce line size.

For installations of rigid piping, short flexible sections of hose should be installed between pump and piping. This reduces vibration and strain to the piping system. A Warren Rupp Tranquillizer® surge suppressor is recommended to further reduce pulsation in flow.

This pump was tested at the factory prior to shipment and is ready for operation. It is completely self-priming from a dry start for suction lifts of 10-15 feet (9-14 meters) or less. For suction lifts exceeding 15 feet of liquid, fill the chambers with liquid prior to priming.

## **AIR SUPPLY**

Air supply pressures cannot exceed 125 psi (8.61 bar). Connect the pump air inlet (see Fig. 1) to an air supply of sufficient capacity and pressure required for desired performance. When the air line is solid piping, use a short length of flexible hose (not less than ¾" [19mm] in diameter) between pump and piping to eliminate strain to pipes.

## **AIR INLET & PRIMING**

For start-up, open an air valve approximately ½ to ¾ turn. After the unit primes, an air valve can be opened to increase flow as desired. If opening the valve increases cycling rate, but does not increase flow rate, cavitation has occurred, and the valve should be closed slightly.

For the most efficient use of compressed air and the longest diaphragm life, throttle the air inlet to the lowest cycling rate that does not reduce flow.

## **A NOTE ABOUT AIR VALVE LUBRICATION**

The SandPIPER pump's pilot valve and main air valve assemblies are designed to operate WITHOUT lubrication. This is the preferred mode of operation. There may be instances of personal preference, or poor quality air supplies when lubrication of the compressed air supply is required. The pump air system will operate with properly lubricated compressed air supplies. Proper lubrication of the compressed air supply would entail the use of an air line lubricator (available from Warren Rupp) set to deliver one drop of 10 wt., non-detergent oil for every 20 SCFM of air the pump consumed at its point of operation. Consult the pump's published Performance Curve to determine this.

It is important to remember to inspect the sleeve and spool set routinely. It should move back and forth freely. This is most important when the air supply is lubricated. If a lubricator is used, oil accumulation will, over time, collect any debris from the compressed air. This can prevent the pump from operating properly.

Water in the compressed air supply can create problems such as icing or freezing of the exhaust air causing the pump to cycle erratically, or stop operating. This can be addressed by using a point of use air dryer (available from Warren Rupp) to supplement a plant's air drying equipment. This device will remove excess water from the compressed air supply and alleviate the icing or freezing problem.

## **ESADS: EXTERNALLY SERVICEABLE AIR DISTRIBUTION SYSTEM**

Please refer to the exploded view drawing and parts list in the Service Manual supplied with your pump. If you need replacement or additional copies, contact your local Warren Rupp Distributor, or the Warren Rupp factory Literature Department at the number shown below. To receive the correct manual, you must specify the MODEL and TYPE information found on the name plate of the pump.

## **MODELS WITH 1" SUCTION/DISCHARGE OR LARGER, AND NON-METAL CENTER SECTIONS**

The main air valve sleeve and spool set is located in the valve body mounted on the pump with four hex head capscrews. The valve body assembly is removed from the pump by removing these four hex head capscrews.

With the valve body assembly off the pump, access to the sleeve and spool set is made by removing a retaining ring (each end) securing the end cap on the valve body assembly. With the end caps removed, slide the spool back and forth in the sleeve. The spool is closely sized to the sleeve and must move freely to allow for proper pump operation. An accumulation of oil, dirt or other contaminants from the pump's air supply, or from a failed diaphragm, may prevent the spool from moving freely. This can cause the spool to stick in a position that prevents the pump from operating. If this is the case, the sleeve and spool set should be removed from the valve body for cleaning and further inspection.

Remove the spool from the sleeve. Using an arbor press or bench vise (with an improvised mandrel), press the sleeve from the valve body. Take care not to damage the sleeve. At this point, inspect the o-rings on the sleeve for nicks, tears or abrasions. Damage of this sort could happen during assembly or servicing. A sheared or cut o-ring can allow the pump's compressed air supply to leak or bypass within the air valve assembly, causing the pump to leak compressed air from the pump air exhaust or not cycle properly. This is most noticeable at pump dead head or high discharge pressure conditions. Replace any of these o-rings as required or set up a routine,

preventive maintenance schedule to do so on a regular basis. This practice should include cleaning the spool and sleeve components with a safety solvent or equivalent, inspecting for signs of wear or damage, and replacing worn components.

To re-install the sleeve and spool set, lightly lubricate the o-rings on the sleeve with an o-ring assembly lubricant or lightweight oil (such as 10 wt. air line lubricant). Press the set into the valve body easily, without shearing the o-rings. Re-install one end cap, and retaining ring on the valve body. Using the arbor press or bench vise that was used in disassembly, press the sleeve back into the valve body. Re-install the spool, keeping the counter-bored end toward you, and install the spring, opposite end cap and retaining ring on the valve body. After inspecting and cleaning the gasket surfaces on the valve body and intermediate, re-install the valve body on the pump using new gaskets. Tighten the four hex head capscrews evenly and in an alternating cross pattern, at 150 in./lbs. (16.94 Newton meters).

## **AIR EXHAUST**

If a diaphragm fails, the pumped liquid or fumes can enter the air end of the pump, and be exhausted into the atmosphere. When pumping hazardous or toxic materials, pipe the exhaust to an appropriate area for safe disposition.

This pump can be submerged if materials of construction are compatible with the liquid. The air exhaust must be piped above the liquid level. Piping used for the air exhaust must not be smaller than 1" (2.54 cm). Reducing the pipe size will restrict air flow and reduce pump performance. When the product source is at a higher level than the pump (flooded suction), pipe the exhaust higher than the product source to prevent siphoning spills.

Freezing or icing of the air exhaust can occur under certain temperature and humidity conditions. Use of a Warren Rupp Extractor/Dryer unit should eliminate most icing problems. Check the exhaust periodically for build-up of ice or contaminants (see Fig. 2).

## **BETWEEN USES**

When used for materials that tend to settle out or transform to solid form, the pump should be completely flushed after each use, to prevent damage. Product remaining in the pump between uses could dry out or settle out. This could cause problems with valves and diaphragms at re-start. In freezing temperatures, the pump must be drained between uses in all cases.

## **FILLING OF DRIVER CHAMBER WITH LIQUID**

The driver chambers are filled at the factory with water.

If you need to substitute another liquid to prevent system contamination, first consult the factory for chemical compatibility with pump construction.

Follow the steps listed below to replace the liquid in the pump after disassembly or liquid loss:

1. Filling is accomplished through the pipe plugs at the top of the liquid driver chamber (see Fig. 3).
2. After the driver fluid has been emptied from the pump, the driver diaphragms will naturally come to center.
3. Remove the entire discharge manifold assembly exposing the ports in the outer diaphragm chambers.
4. Fill either side with 5340 ml. (180.6 fl. oz.) by volume with the driver liquid. It is imperative that the driver liquid chambers be filled with the correct amount of driver liquid as too little or too much will cause premature diaphragm failure and erratic pumping.
5. After filling with the proper amount of liquid, if the liquid does not come to the top of the fill hole, pressure should be applied to the Virgin PTFE diaphragm with a blunt tool through the discharge material flow port in the outer chamber until it does come to the top (see Fig. 4). To facilitate this filling, a taper punch can be used in the hole of the rod to manually shift the pump.
6. When the driver fluid rises to the top of the fill plug hole, screw the boss plug, with o-ring installed, into the chamber (see Fig. 5). (Do not overtighten.) Remember to keep pressure on the Virgin PTFE diaphragm until the boss plug is tight to prevent air from drawing back into the chamber.
7. Filling the opposite side is accomplished in the same manner as described in 5 and 6. The correct amount of fluid will come to the top of the fill hole. Screw in the boss plug.

## CHECK VALVE SERVICING

Need for inspection or service is usually indicated by poor priming, unstable cycling, reduced performance or the pump's cycling but not pumping.

Remove the six flange bolts securing the inlet and outlet flanges to the manifold. Inspect the surfaces of both check valve and seat for wear or damage that could prevent proper sealing. If pump is to prime properly, valves must seat air tight (see Fig. 6).

## DIAPHRAGM SERVICING

### Driver Diaphragms:

Drain the driver diaphragm chamber by removing the boss plug on the underside of the driver chamber. **NOTE:** This is also the part used for leak detector probes. Remove twelve bolts securing the two manifolds to the chambers. Remove eight bolts securing the diaphragm chamber. This permits inspection of the TFE diaphragm and the driver diaphragm. Loosen the plate which secures the diaphragm and plate to the rod by keeping the diaphragm engaged with the inner diaphragm chamber. Insert two or three capscrews through the bolt holes so the diaphragm cannot rotate when loosening. The diaphragm plates, diaphragm and bumper will now come off the assembly. Repeat all actions if the other diaphragm needs to be inspected or replaced.

**NOTE:** See "Filling of Driver Chamber with Liquid" for the correct procedure to recharge the pump for operation.

Reassembly is the reverse of the tear down. During reassembly, be sure the rubber bumper is on the rod on each side. Install the diaphragm with the natural bulge to the outside as marked on the diaphragm. Be sure that the large radius side of each plate is toward the diaphragm. Place the sealing washer between the inner diaphragm plate and the end of the rod. Tighten the plate to approximately 25 ft. lbs. (3.456 pounds/sq. cm.). Torque while allowing the diaphragm to turn freely with the plate. Hold the opposite side with a wrench on the plate to prevent rotation of the rod. If the opposite chamber is assembled, this will not be necessary.

When reassembling the outer chambers and the manifold, the bolts securing the manifold flange to the chamber should be snugged prior to tightening the manifold flange. Finish tightening the manifold flange bolts after the chamber bolting is secured.

## PILOT VALVE

The pilot valve assembly is accessed by removing the main air distribution valve body from the pump and lifting the pilot valve body out of the intermediate housing (see Fig. 9).

Most problems with the pilot valve can be corrected by replacing the o-rings. Always grease the spool prior to inserting it into the sleeve. If the sleeve is removed from the body, reinsertion must be at the chamfered side. Grease the o-rings to slide the sleeve into the valve body. Securely insert the retaining ring around the sleeve. When reinserting the pilot valve, push both plungers (located inside the intermediate bracket) out of the path of the pilot valve spool ends to avoid damage.

## PILOT VALVE ACTUATOR

Bushings for the pilot valve actuators are held in the inner chambers with retaining rings. An o-ring is behind each bushing. If the plunger has any sideways motion check o-rings and bushings for deterioration or wear. The plunger may be removed for inspection or replacement. First remove the air distribution valve body and the pilot valve body from the pump. The plungers can be located by looking into the intermediate. It may be necessary to use a fine piece of wire to pull them out. The bushing can be turned out through the inner chamber by removing the outer chamber assembly. Replace the bushings if pins have bent (see Fig. 10 and Fig. 11).

## **SERVICE INSTRUCTIONS: TROUBLE SHOOTING**

### **1. Pump will not cycle**

- A. Check to make sure the unit has enough pressure to operate and that the air inlet valve is open.
- B. Check the discharge line to insure that the discharge line is neither closed nor blocked.
- C. If the spool in the air distribution valve is not shifting, check the main spool. It must slide freely.
- D. Excessive air leakage in the pump can prevent cycling. This condition will be evident. Air leakage into the discharge line indicates a ruptured diaphragm. Air leakage from the exhaust port indicates leakage in the air distribution valve. See further service instructions.
- E. Blockage in the liquid chamber can impede movement of diaphragm.

### **2. Pump cycles but will not pump**

- A. Suction side of pump pulling in air. Check the suction line for air leaks and be sure that the end of the suction line is submerged. Check flange bolting. Check valve flanges and manifold to chamber flange joints.
- B. Make certain the suction line or strainer is not plugged. Restriction at the suction is indicated by a high vacuum reading when a vacuum gauge is installed in the suction line.
- C. Check valves may not be seating properly. To check, remove the suction line and cover the suction port with your hand. If the unit does not pull a good suction (vacuum), the check valves should be inspected for proper seating.
- D. Static suction lift may be too high. Priming can be improved by elevating the suction and discharge lines higher than the check valves and pouring liquid into the unit through the suction inlet. When priming at high suction lifts or with long suction lines operate the pump at maximum cycle rate.
- E. Incorrect driver fluid level or air has not been properly purged.

### **3. Low performance**

- A. Capacity is reduced as the discharge pressure increases, as indicated on the performance curve. Performance capability varies with available inlet air supply. Check air pressure at the pump inlet when the pump is operating to make certain that adequate air supply is maintained.
  - B. Check vacuum at the pump suction. Capacity is reduced as vacuum increases. Reduced flow rate due to starved suction will be evident when cycle rate can be varied without change in capacity. This condition will be more prevalent when pumping viscous liquids. When pumping thick, heavy materials the suction line must be kept as large in diameter and as short as possible, to keep suction loss minimal.
  - C. Low flow rate and slow cycling rate indicate restricted flow through the discharge line. Low flow rate and fast cycling rate indicate restriction in the suction line or air leakage into suction.
  - D. Unstable cycling indicates improper check valve seating on one chamber. This condition is confirmed when unstable cycling repeats consistently on alternate exhausts. Cycling that is not consistently unstable may indicate partial exhaust restriction due to freezing and thawing of exhaust air. Use of an anti-freeze lubricant in an air line lubricator should solve this problem.
  - E. Incorrect driver fluid level or air has not been properly purged.
- For additional information, see the Warren Rupp Trouble Shooting Guide.

## **WARRANTY**

This pump is warranted for a period of five years against defective material and workmanship. Failure to comply with the recommendations stated in this manual voids all factory warranty.





# SERVICE AND OPERATING MANUAL



Original Instructions

## ET3 - M

### CONTAINMENT DUTY Type 1

ITEM NO.	PART NUMBER	DESCRIPTION	TOTAL RQD.
1	070.006.170	Bearing, Sleeve	2
2	114.002.156	Bracket, Intermediate	1
	114.002.010	Bracket, Intermediate	2
3	<b>720.004.360</b>	<b>Seal, U-Cup</b>	<b>2</b>
4	<b>135.016.162</b>	<b>Bushing, Threaded</b>	<b>2</b>
5	<b>620.011.114</b>	<b>Plunger, Actuator</b>	<b>2</b>
6	<b>095.073.000</b>	<b>Pilot Valve Body Assembly*</b>	<b>1</b>
6.A	<b>095.070.558</b>	<b>Pilot Valve Body</b>	<b>1</b>
6.B	<b>755.025.000</b>	<b>Sleeve (with O-Ring)</b>	<b>1</b>
6.C	<b>560.033.360</b>	<b>O-Ring (Sleeve)</b>	<b>4</b>
6.D	<b>775.026.000</b>	<b>Spool (with O-Ring)</b>	<b>1</b>
6.E	<b>560.023.360</b>	<b>O-Ring (Spool)</b>	<b>2</b>
6.F	<b>675.037.080</b>	<b>Retaining Ring</b>	<b>1</b>
7	<b>360.041.425</b>	<b>Gasket, Valve Body</b>	<b>1</b>
9	095.043.156	Body, Valve (AL)	1
	095.043.010	Body, Valve (CI)	1
10	<b>132.014.358</b>	<b>Bumper, Valve Spool</b>	<b>2</b>
11	165.066.010	Cap, End	2
12	<b>360.048.425</b>	<b>Gasket, Valve Body</b>	<b>1</b>
13	<b>360.010.425</b>	<b>Gasket, End Cap</b>	<b>2</b>
14	<b>560.020.360</b>	<b>O-Ring</b>	<b>6</b>
15	<b>031.069.000</b>	<b>Sleeve &amp; Spool Set</b>	<b>1</b>
16	170.032.330	Capscrew Hex Head	8
17	170.045.330	Capscrew, Hex Head	4
18	<b>132.002.360</b>	<b>Bumper, Diaphragm</b>	<b>2</b>
19	196.100.010	Chamber Inner	2
20	<b>560.001.360</b>	<b>O-Ring</b>	<b>2</b>
21	<b>560.022.360</b>	<b>O-Ring</b>	<b>2</b>
22	<b>685.041.120</b>	<b>Rod, Diaphragm</b>	<b>1</b>
24	170.024.330	Capscrew Hex Head	8
25	530.008.000	Muffler, Exhaust	1
26	900.006.330	Washer, Lock	8
27	545.008.330	Nut, Hex	16
28	900.003.330	Washer, Lock	32
29	612.124.010	Plate, Inner Diaphragm	2
30	<b>286.098.354</b>	<b>Diaphragm</b>	<b>2</b>
	286.098.365	Diaphragm	2
	286.098.363	Diaphragm	2
	286.098.360	Diaphragm	2
	286.098.364	Diaphragm	2
31	722.041.365	Seat, Valve	4
	722.041.360	Seat, Valve	4
	722.041.363	Seat, Valve	4
	722.041.364	Seat, Valve	4
	722.041.600	Seat, Valve	4

Repair Parts shown in **bold face (darker)** type are more likely to need replacement after extended periods of normal use. They are readily available from most Warren Rupp distributors. The pump owner may prefer to maintain a limited inventory of these parts in his own stock to reduce repair downtime to a minimum.

**IMPORTANT:** When ordering repair parts always furnish pump model number, serial number and type number.

ITEM NO.	PART NUMBER	DESCRIPTION	TOTAL RQD.
32	<b>050.014.365</b>	<b>Ball, Check Valve</b>	<b>4</b>
	050.014.364	Ball, Check Valve	4
	050.014.360	Ball, Check Valve	4
	050.015.600	Ball, Check Valve	4
36	518.123.156	Manifold, Suction (AL)	1
	518.123.110	Manifold, Suction (SS)	1
37	518.124.156	Manifold, Discharge (AL)	1
	518.124.110	Manifold, Discharge (SS)	1
38	170.055.330	Capscrew, Hex Head	12
39	326.002.080	Mounting Foot	2
40	286.067.354	Diaphragm, Pumping	2
	286.067.365	Diaphragm, Pumping	2
	286.067.360	Diaphragm, Pumping	2
	286.067.363	Diaphragm, Pumping	2
	286.067.364	Diaphragm, Pumping	2
	286.068.604	Diaphragm, Pumping	2
41	170.034.330	Capscrew, Hex Head	12
43	196.052.156	Chamber, Outer (AL)	2
	196.052.110	Chamber, Outer (SS)	2
44	612.090.156	Plate, Outer Diaphragm Assembly	2
52	170.102.330	Capscrew, Hex Head (AL only)	16
	170.102.115	Capscrew, Hex Head (SS only)	12
53	196.136.156	Chamber	2
	196.136.110	Chamber	2
	196.141.156	Chamber	2
		(PTFE overlay and PTFE pumping)	2
	196.141.110	Chamber	2
		(PTFE overlay and PTFE pumping)	2
54	426.042.000	Hose Assembly	2
55	866.059.115	Fitting, Male	4
56	618.003.110	Plug, Pipe	6
57	835.005.115	Tee, Pipe	4
58	538.083.115	Nipple, Pipe	4
60	618.025.115	Boss Plug and O-Ring	2
61	210.008.330	Clip, Safety	1
62	866.060.110	Connector (SS only)	4
63	860.047.606	Tube, Sight	2
64	807.042.115	Stud	8
65	560.023.360	O-Ring, End Cap	2

Not Shown:

031.090.156	Main Air Valve Assembly (AL) (Includes Items 9, 10, 11, 13, 14, 15, 16 & 61)	1
031.090.010	Main Air Valve Assembly (SS) (Includes Items 9, 10, 11, 13, 14, 15, 16 & 61)	1

\* Item 6 is available in kit form. Order P/N 031.055.000 which also includes Items 5, 7, 12, & 20.

475-128-000	AIR END KIT Seals, O-Rings, Gaskets, Air Valve Sleeve and Spool, Pilot Valve Assembly
475-120-360	WETTED END KIT Buna Diaphragms, Check Balls and Seats
475-120-635	WETTED END KIT wwPTFE Pumping Diaphragms, Check Balls and Seats, Neoprene Driver Diaphragm

Repair Parts shown in **bold face (darker)** type are more likely to need replacement after extended periods of normal use. They are readily available from most Warren Rupp distributors. The pump owner may prefer to maintain a limited inventory of these parts in his own stock to reduce repair downtime to a minimum.

**IMPORTANT:** When ordering repair parts always furnish pump model number, serial number and type number.

Note: For models using Virgin PTFE pumping diaphragms, (Item 40) the natural bulge goes toward the center of the pump.

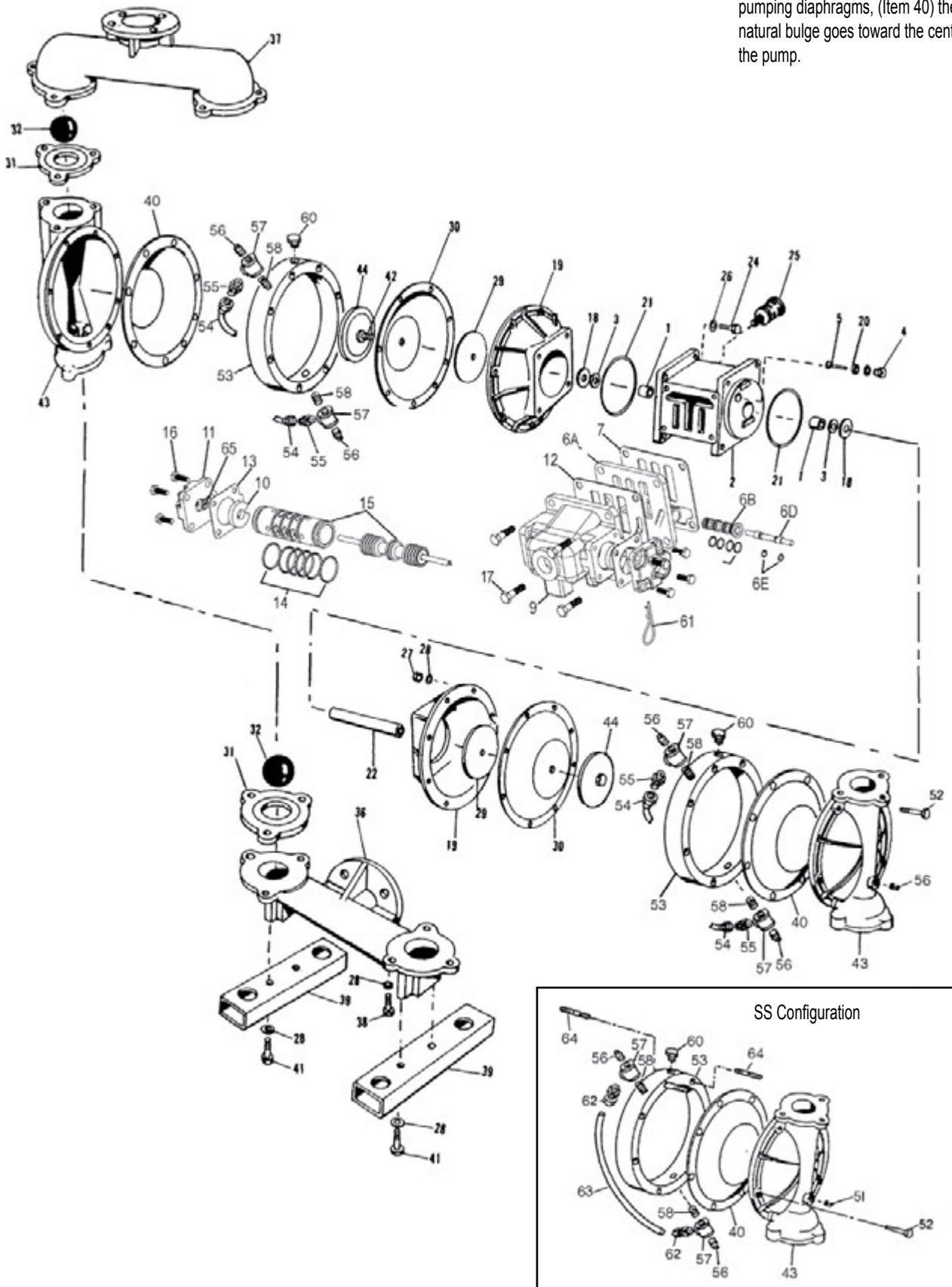

# Safety Information

## IMPORTANT



Read the safety warnings and instructions in this manual before pump installation and start-up. Failure to comply with the recommendations stated in this manual could damage the pump and void factory warranty.



When the pump is used for materials that tend to settle out or solidify, the pump should be flushed after each use to prevent damage. In freezing temperatures the pump should be completely drained between uses.

## CAUTION



Before pump operation, inspect all fasteners for loosening caused by gasket creep. Retighten loose fasteners to prevent leakage. Follow recommended torques stated in this manual.



Nonmetallic pumps and plastic components are not UV stabilized. Ultraviolet radiation can damage these parts and negatively affect material properties. Do not expose to UV light for extended periods of time.



### **WARNING**

Pump not designed, tested or certified to be powered by compressed natural gas. Powering the pump with natural gas will void the warranty.



### **WARNING**

The use of non-OEM replacement parts will void (or negate) agency certifications, including CE, ATEX, CSA, 3A and EC1935 compliance (Food Contact Materials). Warren Rupp, Inc. cannot ensure nor warrant non-OEM parts to meet the stringent requirements of the certifying agencies.

## WARNING



When used for toxic or aggressive fluids, the pump should always be flushed clean prior to disassembly.



Before maintenance or repair, shut off the compressed air line, bleed the pressure, and disconnect the air line from the pump. Be certain that approved eye protection and protective clothing are worn at all times. Failure to follow these recommendations may result in serious injury or death.



Airborne particles and loud noise hazards. Wear eye and ear protection.



In the event of diaphragm rupture, pumped material may enter the air end of the pump, and be discharged into the atmosphere. If pumping a product that is hazardous or toxic, the air exhaust must be piped to an appropriate area for safe containment.



Take action to prevent static sparking. Fire or explosion can result, especially when handling flammable liquids. The pump, piping, valves, containers and other miscellaneous equipment must be properly grounded.



This pump is pressurized internally with air pressure during operation. Make certain that all fasteners are in good condition and are reinstalled properly during reassembly.



Use safe practices when lifting

## RECYCLING

Many components of SANDPIPER® AODD pumps are made of recyclable materials. We encourage pump users to recycle worn out parts and pumps whenever possible, after any hazardous pumped fluids are thoroughly flushed.

## MATERIAL CODES THE LAST 3 DIGITS OF PART NUMBER

000	Assembly, sub-assembly; and some purchased items	353	Geolast; Color: BLACK	557	Conductive Polypropylene; Color: BLACK; Color Coded: SILVER
010	Cast Iron	354	Injection Molded #203-40 Santoprene- Duro 40D +/-5; Color: RED	558	Conductive HDPE; Color: BLACK Color Coded: SILVER
012	Powered Metal	355	Thermal Plastic	559	Conductive Polypropylene; Color: BLACK Color Coded: SILVER
015	Ductile Iron	356	Hytre; Color: BLUE	570	Rulon II
020	Ferritic Malleable Iron	357	Injection Molded Polyurethane; Color: GREEN	580	Ryton
025	Music Wire	358	Urethane Rubber; Color: NATURAL (Some Applications) (Compression Mold)	590	Valox
080	Carbon Steel, AISI B-1112	359	Urethane Rubber; Color: NATURAL	591	Nylatron G-S
100	Alloy 20	360	Nitrile Rubber; Color Coded: RED	592	Nylatron NSB
110	Alloy Type 316 Stainless Steel	361	Nitrile	600	PTFE (virgin material) Tetrafluorocarbon (TFE)
111	Alloy Type 316 Stainless Steel (Electro Polished)	363	FKM (Fluorocarbon). Color Coded: YELLOW	601	PTFE (Bronze and moly filled)
112	Alloy C	364	E.P.D.M. Rubber. Color Coded: BLUE	602	Filled PTFE
113	Alloy Type 316 Stainless Steel (Hand Polished)	365	Neoprene Rubber; Color Coded: GREEN	603	Blue Gylon
114	303 Stainless Steel	366	Food Grade Nitrile; Color: WHITE	604	PTFE
115	302/304 Stainless Steel	368	Food Grade EPDM; Color: GRAY	606	PTFE
117	440-C Stainless Steel (Martensitic)	370	Butyl Rubber Color Coded: BROWN	607	Envelon
120	416 Stainless Steel (Wrought Martensitic)	371	Philthane (Tuftane)	608	Conductive PTFE; Color: BLACK
123	410 Stainless Steel (Wrought Martensitic)	374	Carboxylated Nitrile	610	PTFE Encapsulated Silicon
148	Hardcoat Anodized Aluminum	375	Fluorinated Nitrile	611	PTFE Encapsulated FKM
149	2024-T4 Aluminum	378	High Density Polypropylene	632	Neoprene/Hytre
150	6061-T6 Aluminum	379	Conductive Nitrile; Color Coded: RED & SILVER	633	FKM/PTFE
151	6063-T6 Aluminum	384	Conductive Neoprene; Color Coded: GREEN & SILVER	634	EPDM/PTFE
152	2024-T4 Aluminum (2023-T351)	405	Cellulose Fibre	635	Neoprene/PTFE
154	Almag 35 Aluminum	408	Cork and Neoprene	637	PTFE , FKM/PTFE
155	356-T6 Aluminum	425	Compressed Fibre	638	PTFE , Hytre/PTFE
156	356-T6 Aluminum	426	Blue Gard	639	Nitrile/TFE
157	Die Cast Aluminum Alloy #380	440	Vegetable Fibre	643	Santoprene®/EPDM
158	Aluminum Alloy SR-319	465	Fibre	644	Santoprene®/PTFE
159	Anodized Aluminum	500	Delrin 500	656	Santoprene Diaphragm and Check Balls/EPDM Seats
162	Brass, Yellow, Screw Machine Stock	501	Delrin 570	661	EPDM/Santoprene
165	Cast Bronze, 85-5-5-5	502	Conductive Acetal, ESD-800; Color: BLACK	666	FDA Nitrile Diaphragm, PTFE Overlay, Balls, and Seals
166	Bronze, SAE 660	503	Conductive Acetal, Glass-Filled Color: BLACK; Color Coded: YELLOW	668	PTFE, FDA Santoprene/PTFE
170	Bronze, Bearing Type, Oil Impregnated	505	Acrylic Resin Plastic		
175	Die Cast Zinc	506	Delrin 150		
180	Copper Alloy	520	Injection Molded PVDF; Color: NATURAL		
305	Carbon Steel, Black Epoxy Coated	521	Injection Molded Conductive PVDF; Color: BLACK; Color Coded: LIGHT GREEN		
306	Carbon Steel, Black PTFE Coated	540	Nylon		
307	Aluminum, Black Epoxy Coated	541	Nylon		
308	Stainless Steel, Black PTFE Coated	542	Nylon		
309	Aluminum, Black PTFE Coated	544	Nylon Injection Molded Polyethylene		
310	PVDF Coated	551	Glass Filled Polypropylene; Color: BLACK		
313	Aluminum, White Epoxy Coated	552	Unfilled Polypropylene; Color: NATURAL		
330	Zinc Plated Steel	555	Polyvinyl Chloride		
331	Chrome Plated Steel	556	Black Vinyl		
332	Aluminum, Electroless Nickel Plated				
333	Carbon Steel, Electroless Nickel Plated				
335	Galvanized Steel				
336	Zinc Plated Yellow Brass				
337	Silver Plated Steel				
340	Nickel Plated				
342	Filled Nylon				
351	Food Grade Santoprene; Color: NATURAL				

Delrin is a registered  
tradename of E.I. DuPont.

Gylon is a registered tradename  
of Garlock, Inc.

Nylatron is a registered tradename  
of Polymer Corp.

Santoprene is a registered tradename  
of Exxon Mobil Corp.

Rulon II is a registered tradename  
of Dixon Industries Corp.

Ryton is a registered tradename  
of Phillips Chemical Co.

Valox is a registered tradename  
of General Electric Co.

PortaPump, Tranquilizer and SludgeMaster are  
registered tradenames of Warren Rupp, Inc.

# 5 - YEAR Limited Product Warranty

Warren Rupp, Inc. ("Warren Rupp") warrants to the original end-use purchaser that no product sold by Warren Rupp that bears a Warren Rupp brand shall fail under normal use and service due to a defect in material or workmanship within five years from the date of shipment from Warren Rupp's factory. Warren Rupp brands include Warren Rupp®, SANDPIPER®, SANDPIPER Signature Series™, MARATHON®, Porta-Pump®, SludgeMaster™ and Tranquilizer®.

The use of non-OEM replacement parts will void (or negate) agency certifications, including CE, ATEX, CSA, 3A and EC1935 compliance (Food Contact Materials). Warren Rupp, Inc. cannot ensure nor warrant non-OEM parts to meet the stringent requirements of the certifying agencies.

~ See [sandpiperpump.com/content/warranty-certifications](http://sandpiperpump.com/content/warranty-certifications) for complete warranty, including terms and conditions, limitations and exclusions. ~

**WARREN  
RUPP, INC.**

## Declaration of Conformity

**Manufacturer: Warren Rupp, Inc., 800 N. Main Street  
Mansfield, Ohio, 44902 USA**

Certifies that Air-Operated Double Diaphragm Pump Series: HDB, HDF, M Non-Metallic, S Non-Metallic, M Metallic, S Metallic, T Series, G Series, U Series, EH and SH High Pressure, RS Series, W Series, SMA and SPA Submersibles, and Tranquilizer® Surge Suppressors comply with the European Community Directive 2006/42/EC on Machinery, according to Annex VIII. This product has used Harmonized Standard EN809:1998+A1:2009, Pumps and Pump Units for Liquids - Common Safety Requirements, to verify conformance.

David Roseberry  
Signature of authorized person

David Roseberry  
Authorised Representative:  
IDEX Pump Technologies  
R79 Shannon Industrial Estate,  
Shannon, Co. Clare  
Ireland

October 20, 2005  
Date of issue

Engineering Manager  
Title

February 27, 2017  
Date of revision



Revision Level: F

