

SERVICE & OPERATING MANUAL

WARREN RUPP, INC.

ELECTRONIC LEAK DETECTOR



032-044-000 } 12-32 VDC
032-045-000 }

SPECIFICATIONS

032-044-000 and 032-045-000

Power Supply:
12-32VDC

Probe Supply:
4 Volts, 6KHz AC Max. (44 Microamps to 7.8 Milliamps)

The Warren Rupp Electronic Leak Detector consists of a modular control unit encased in a watertight enclosure, two detection probes, and a watertight enclosure. All of these items are wired together as noted on the schematic illustration Figure A on page 2.

The Warren Rupp Electronic Leak Detector senses pumped liquid entering either the inert fluid-filled spill containment chambers of the pumps, or the inner chambers of standard pumps.

SANDPIPER® Containment Duty (spill containment) pumps are designed with a two-fold purpose:

1. In the event of a ruptured pumping diaphragm, the pumped fluid is prevented from entering the compressed air system of the pump because it is contained by a second diaphragm.
2. In the event of a driver diaphragm failure, only the inert filler fluid in the spill containment chamber is exhausted through the muffler. The pumped liquid is prevented from entering the air system and the environment by the pumping diaphragm, and compressed air is prevented from contaminating the pumped liquid.

When the Warren Rupp Electronic Leak Detector is installed in the inert fluid-filled spill containment chamber, it provides an early warning of failure of the pumping diaphragm.

The leak detector works on the principle of

WARNING



Hazardous voltage. This Leak Detector is an electrical device. It should be wired by only qualified, licensed electricians. The cover should never be removed except by authorized, licensed electricians. Failure to heed this warning may result in electric shock, personal lasting injury or death.

Power shall be disconnected before enclosure is opened.

Enclosure shall be closed before power is restored.

conductance. The probe is installed into the bottom-most 1/4" NPT pipe tee on SANDPIPER pumps equipped with the Containment Duty spill containment option, or through the bottom boss in the spill containment chamber on SANDPIPER Model ST1-A and ST1½-A pumps. When the pumping diaphragm fails, the probe is exposed to the pumped liquid. This produces a low current of 1.2 volts DC (<1 milliamp) which signals the control unit. One of two indicator lights signal which pumping diaphragm has failed and which spill containment chamber has been contaminated by the pumped fluid.

The control unit can easily be wired to an audible alarm or a pump shutdown mechanism. An optional External Output Junction is available, allowing the leak detector to be mounted near the pump or in a remote location. The 3-lead wire part number 150-027-000 is supplied in 15-foot lengths and the probe assembly part number 628-002-000 (2 required) in 2-foot lengths.

When the Warren Rupp Electronic Leak Detector is installed on **standard** pumps (without spill containment) the probes are inserted into the bottom boss plugs on the inner chambers.

NOTE: The Warren Rupp Leak Detector will detect any moisture that pools at the bottom of the inner chamber. Air supplies with high moisture content will deposit at the bottom of the inner chamber. This will cause the probe to send false signals of diaphragm rupture to the control unit. When the leak detector is used to detect diaphragm failure it is recommended that an air dryer be installed in the air supply line to lessen the chance of false signals.

Probe Installation

To install the probe, first back-twist the cable counterclockwise to avoid wire twist when the probe is treaded clockwise into the 1/4" NPT tees or ports. Apply PTFE tape or a small amount of thread sealant to the threads prior to insertion.

NOTE: When the leak detector is installed on Models SET1 and SET2, the probes must be fitted into special boss plug kits. Order one Boss Plug Kit 475-098-000 per pump.

Electronic Leak Detector	Used on Models
032-044-000	SB1, SB1½, SB2, SB3 ST1, ST1½, SSB1, SSB2 SET1 and SET2 ET1, ET1½

Wire Instructions (Schematic)

Warren Rupp does not supply a power cord due to the many various lengths that may be necessary to get the appropriate voltage source. We do recommend that a 3-lead wire of 14-gauge minimum be used to hook into the detection box. One end of the box has a single 7/8" diameter hole common to electrical boxes. The power cord should be wired into the box as the schematic (Figure C) shows. The connection is in the cover area. Terminals are marked + - and G (ground). Your detection system should now be ready for use.

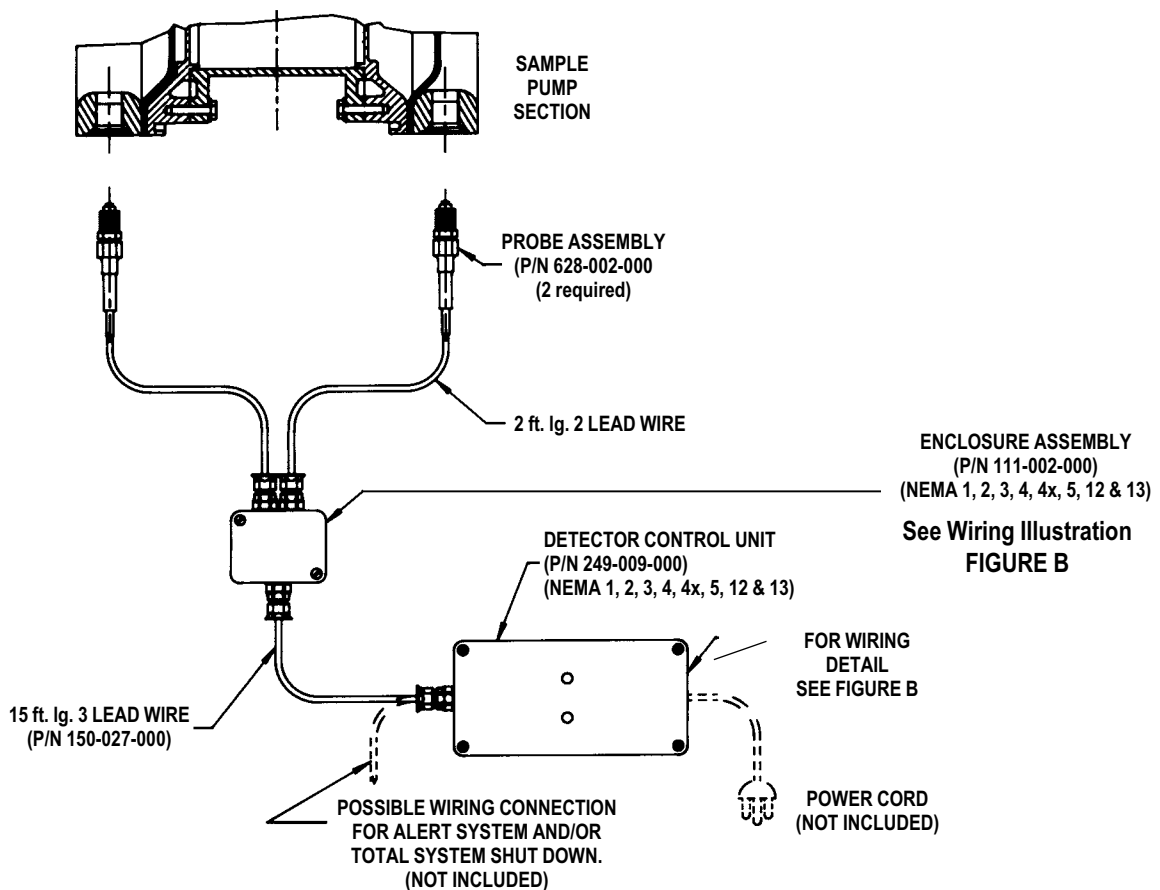

WIRING ILLUSTRATION
FIGURE A

Electronic Leak Detector	Used on Models
032-045-000	S15, S20, S30 non-metallic M15, M20, M30 non-metallic M1F and S1F non-metallic

To install electronic leak detectors, remove the bottom 1/4" NPT pipe plug on the visual sight tube. Insert leak detector into the 1/4" pipe tee.

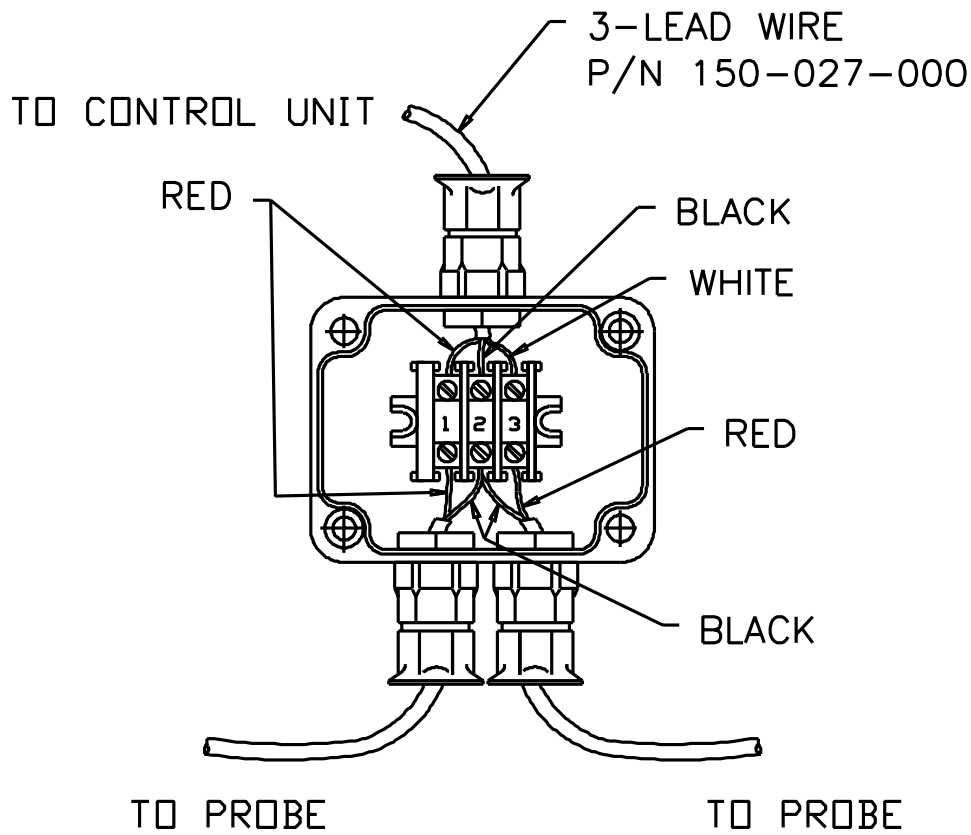

WIRING ILLUSTRATION
FIGURE B

Options:

Available, as stated under principle of operation, is an external output junction. If you wish to connect the detection device to a solenoid which can shut off air to the pump for example, or ring a bell, wire into the box for this external connection thru the 7/8" diameter hole (commonly plugged) located on the same end as the probe wire. The output connection terminal has 100 watt power output and each chamber

has independent connections. If combining the two chambers, a four-wire lead, spliced before the external device would be necessary. (See output connection terminal Figure E.)

When Leak Detector is used with spill containment Models SET1-A and SET2-A, the probes must be fitted into special boss plugs. Order one Boss Plug Kit 475-098-000 per pump.

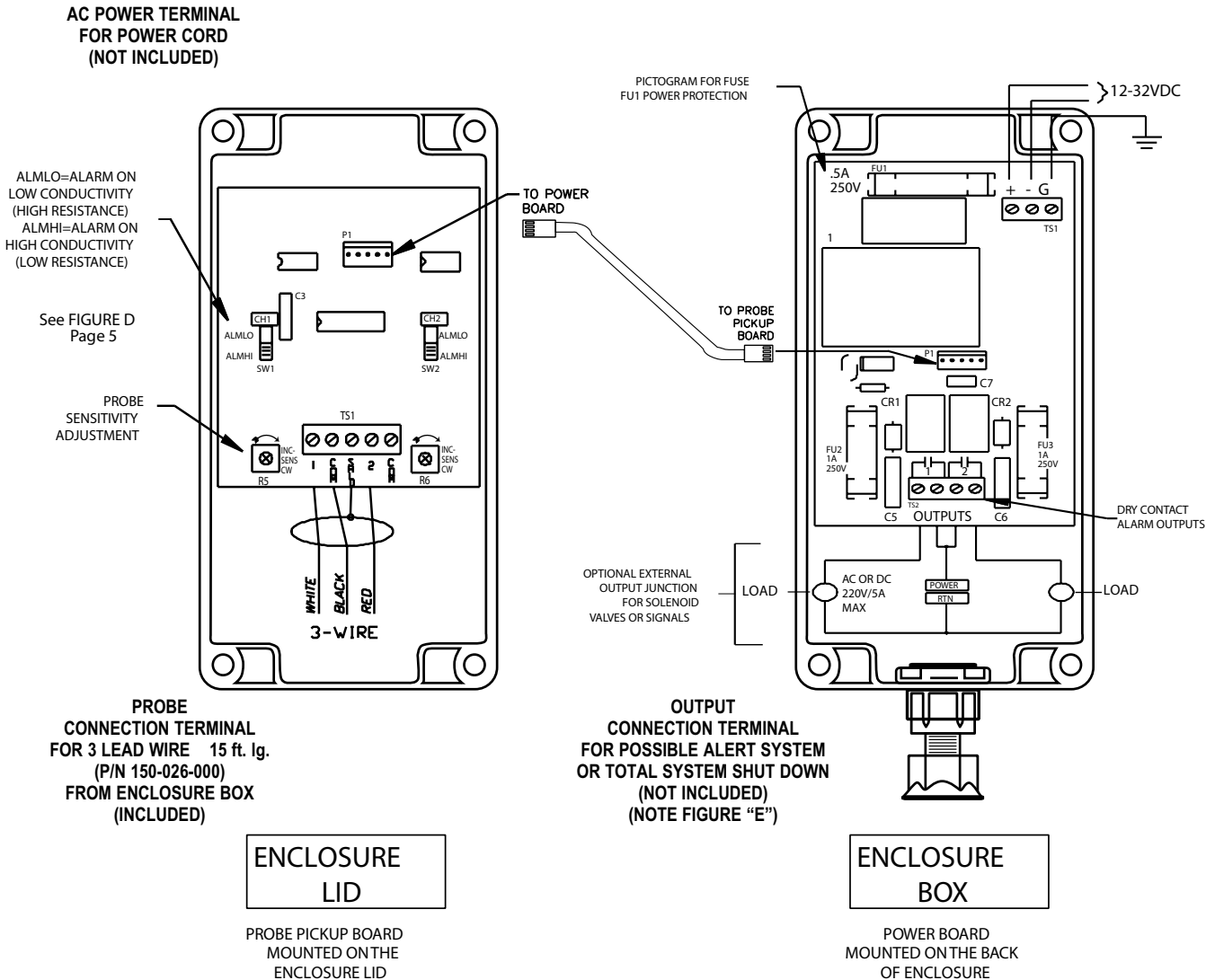

FIGURE C

Conductivity:

The leak detector probes work under the principle of conductance. Not all pumped liquid is conductive, such as when using this device with a Containment Duty (spill containment) type SANDPIPER® pump. Ideally, if the pumped product is conductive, then the driver fluid should be non-conductive. The driver fluid must be compatible with the driver diaphragm and be compatible with the pumped product. If the pumping diaphragm fails, the pumped product will conduct (complete the circuit) and signal the box and the warning light will come on. If the reverse is required, such as pumping non-conductive fluid, the driver fluid should be conductive. If this is the case, move the two switches located in the cover marked SW1 and SW2, to the opposite locations. (See the close-up Figure D).

Sensitivity of this detector can be adjusted by the adjusting knobs R5 and R5. (See Figure D.) These adjusting knobs work independently for each side (chamber). They can be moved with a small screwdriver. These sensitivity knobs are also important in setting to detect conductance fluid at the sensitivity most required. The sensitivity range of the detector is adjustable from 500 OHM (2,000 Micro MHO) to 100,000 OHM (10 Micro MHO).

When sensing low conductivity, turning the screws clockwise increases probe sensitivity.

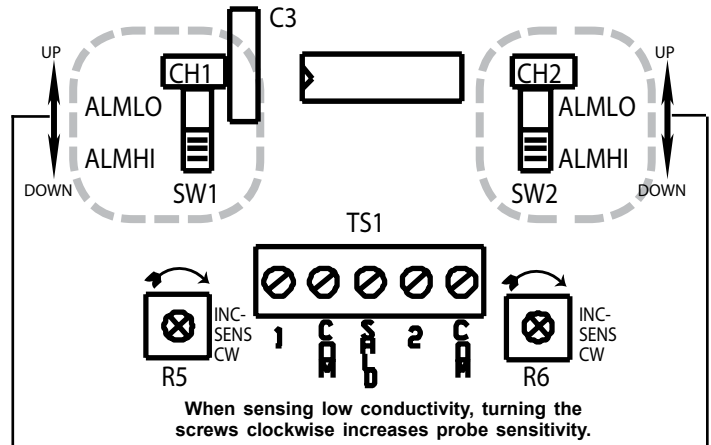

Conductive/Non-Conductive Switch Information

Note: Pumps containing driver fluid should be filled with conductive or non-conductive fluid, depending on the fluid pumped. The driver fluid should be opposite of the pumped product in order to determine diaphragm failure and light warning LED signal(s). This is adjusted inside the box in the following manner:

SW1 DOWN (LED 1) = LED on w/presence of conductive fluid and off w/absence of conductive fluid.

SW1 UP (LED 1) = LED on w/absence of conductive fluid and off w/absence of conductive fluid.

— OR —

SW2 DOWN (LED 2) = LED on w/absence of conductive fluid and off w/presence of conductive fluid.

SW2 UP (LED 2) = LED on w/presence of conductive fluid and off w/absence of conductive fluid.

FIGURE D

(See ENCLOSURE LID, Figure C)
Page 4

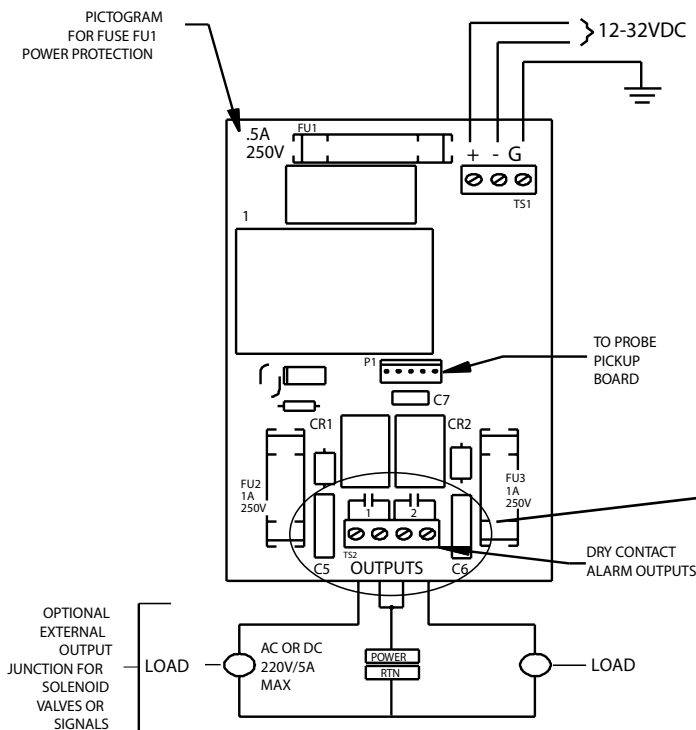
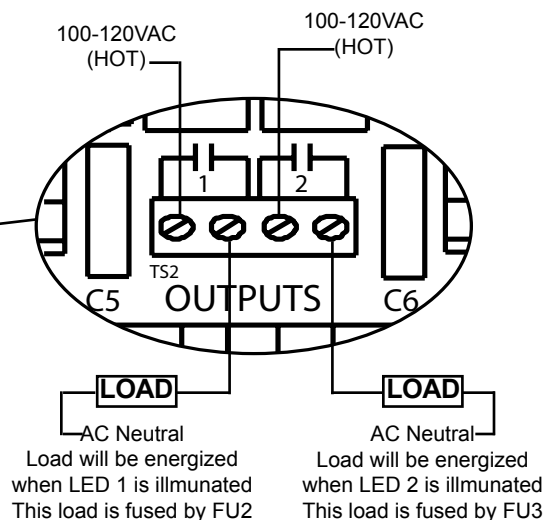

FIGURE E



Copyright ©2009 Warren Rupp. All rights reserved.
Warren Rupp® and SANDPIPER® are tradenames of IDEX AODD, Inc.

