

# V.I.P. Leak Detector

## Operating & Service Instructions



**V.I.P. Leak Detector**

This Warren Rupp Leak Detector is an air valve of special design, with compressed air introduced into the device through an inlet port. An open air flow condition, resulting from the opening of the normally-closed outlet port, occurs when the device is actuated.

Actuation occurs when the threaded male end portion is exposed to any liquid that is incompatible with an O-Ring component. Degradation of the O-Ring releases a spring loaded actuator to open the outlet port and operate a warning light, alarm or other air operated signal device (supplied by user).

When inserted into the liquid-filled chambers of VIP SandPIPER pumps, the VIP Leak Detector can be used to indicate the failure of the outer diaphragm which separates the pumped liquid from the driver chamber liquid.

### PRINCIPLE OF OPERATION

The V.I.P. Leak Detector uses a spring loaded connector pin retained by an O-Ring made from one of several possible materials. The O-Ring material to be used is determined by past experience or testing (by the user) to determine which material is most adversely affected by the liquid being pumped. Adverse effects include swelling of the O-Ring, change in physical properties of the O-Ring material, or disintegration of the O-Ring.

When the O-Ring has been sufficiently affected, the spring loaded plunger moves upward and activates an air control valve, releasing the pilot air to signal diaphragm rupture by means of a warning device (alarm, flashing light— warning devices not included) or by shutting off the pump.

Because of the several variables involved—aggressiveness of the pumped liquid, pumping rate, its degree of incompatibility with the selected O-Ring material, the volume of intrusive liquid in the driver chamber as determined by the size of the puncture or split in the pumping diaphragm, plus others—the elapsed time between diaphragm failure and actuation of the Leak Detector is subject to variation. The elapsed time could range from seconds to hours, or longer. Prior testing by the user is required to determine degree of variation and if operation will be satisfactory for a given application.

### SELECTION OF O-RING MATERIAL

Selection of the proper O-Ring material requires two steps. First, check the Warren Rupp Chemical Resistance Bulletin for elastomer(s) rated X. Second, take from the O-Ring test kit one O-Ring of each elastomer rated X and place one on the leak detector. Remove the detector housing (Item 2) (the two holes contained on Item 2 are for visual inspection of the plungers only) exposing the spring loaded connector pin. Submerge the O-Ring end of the Leak Detector into a sample of the liquid that is to be pumped. Submerge the detector to a position only slightly above the O-Ring. **DO NOT TOTALLY SUBMERGE THE LEAK DETECTOR.** Repeat for each "X" rated O-Ring. Determine which O-Ring material loses retention of the connector most quickly, and use O-Rings of this material during operation. **EXTREME CARE SHOULD BE TAKEN WITH HAZARDOUS LIQUIDS.** After testing the O-Ring(s) rinse the detector(s) with a clean, compatible fluid and wipe dry.

### INSTALLATION

When installing the V.I.P. Leak Detector on a V.I.P. SandPIPER pump which is already in service, use extreme caution. Be certain that the inlet air pressure to the pump is disconnected. Also, be sure to

close all inlet and discharge valves on the liquid piping to the pump.

Once the proper O-Ring (Item 4) has been selected and secured over the connector pin (Item 3-4) the Leak Detector can be installed on a 1" or 1½" V.I.P. SandPIPER pump. Leak Detector assembly 031-026-000 is used on the 1" V.I.P. Leak Detector. Assembly 031-025-000 is used on the 1½" V.I.P.

1. Remove the pipe plugs at the top of the V.I.P. liquid filled inner chambers. Be careful not to lose any fluid from the inner chamber.
2. Thread the assembled Leak Detector, with O-Ring in place, into the inner chamber (in place of pipe plug) after making sure all air is evacuated from chamber. This is described in Steps 1-7 of the V.I.P. Service Manual under **Filling of Driver Chamber with Liquid.** Use Teflon pipe sealant or equal. **DO NOT USE TEFLON TAPE.**
3. Use the same procedure for opposite side. NOTE: O-Ring should also be checked for compatibility with driver fluid, to assure that it is not adversely affected by the driver fluid.
4. Make sure the top half of Leak Detector (Items 1 & 2) fits snugly into the threaded bushing (Item 3-3). Connect an air supply hose to the top (inlet) of the control valve (Item 1) from an air supply (not to exceed 100 psi).
5. Connect an air hose to the side (outlet) port of the control valve (Item 1) and direct it to the alarm or control system. Both inlet and outlet ports are #10-32 thread size.

### SERVICE INSTRUCTIONS

WHEN SERVICE IS REQUIRED ON THE V.I.P. LEAK DETECTOR IT IS AGAIN IMPORTANT TO MAKE CERTAIN THAT INLET AIR PRESSURE TO BOTH LEAK DETECTORS AND TO THE PUMP IS DISCONNECTED. ALSO, BE SURE TO CLOSE ALL INLET AND DISCHARGE VALVES ON THE LIQUID PIPING TO THE PUMP. The O-Ring (Item 4) must be replaced after each activation of the Leak Detector. To do this, carefully remove the detector from the inner chamber. **Extreme care should be taken when dealing with a hazardous liquid.** Once the detector has been removed, it must be rinsed with a clean, compatible fluid. Then remove the detector housing (Item 2), with the control valve (Item 1) still in place, from the threaded bushing (Item 3-3). This exposes the spring loaded connector pin (Item 3-4). Push the pin down and wipe the head dry. While the pin is still down

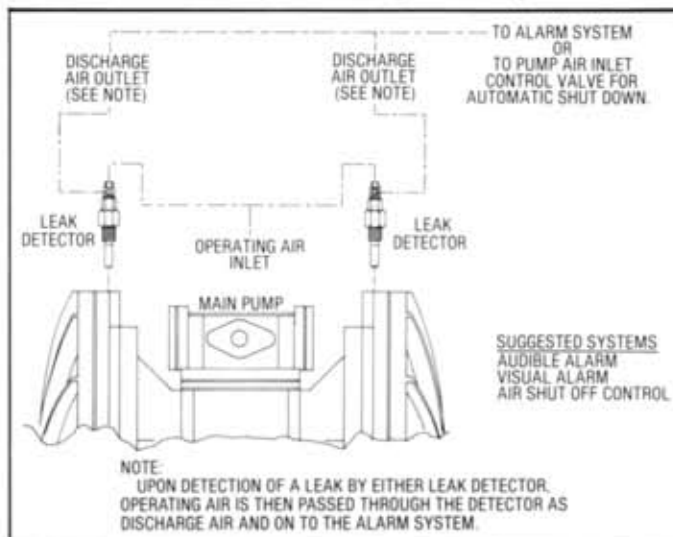

**V.I.P. Leak Detector installed**

slip a new O-Ring over the head and into the groove on the head. Then slowly release the connector pin. The connector pin should now be retained in the loaded position.

Replace the detector housing into the threaded bushing and the detector is ready to be installed.

**WARRANTY** — This unit is guaranteed for a period of one year against defective material and workmanship.

**IMPORTANT:**

Warren Rupp, Inc. does not guarantee that the Leak Detector will function to activate a warning device within any definite period of time. Pumping rate, agitation within the liquid-filled chamber, size of puncture in the diaphragm, aggressive nature of the pumped liquid, temperature variations plus other circumstances can affect the degradation rate of the o-ring and the subsequent activation of the warning device. It is the responsibility of the user to determine through tests if the Leak Detector will perform dependably with time intervals to satisfy requirements on any specific application. The user should further understand that should a driver diaphragm fail, the product and/or fumes from the product being pumped can enter the air side of the pump. The air side of the pump is exhausted through the exhaust port (muffler).

When the product being pumped is a hazardous or toxic material, the exhaust should be piped to an appropriate area for safe disposition.

When the product being pumped is at a level above the pump (flooded suction), the exhaust should be piped to a higher level than the product in order to prevent spillage caused by siphoning.

**REPAIR PARTS LIST**  
**1" & 1½" V.I.P. LEAK DETECTOR**

1" V.I.P. Leak Detector (031-024-110) and 1½" V.I.P. Leak Detector (031-023-110). Two Leak Detectors required per pump.

ITEM	PART NUMBER		RQD.
1	893-050-162	Valve, Control	1
2	430-029-162	Housing, Detector	1
3	*031-025-000	Lower Housing Service Kit (for ST1-A only)(Consisting of:)	1
3-1		Klipring	(1)
3-2		Spring	(1)
3-3		Spring Loaded Seal	(1)
3-4		Bushing, Threaded Assembly	(1)
3	*031-026-000	Pin, Connector	(1)
3		Lower Housing Service Kit (for ST1½-A only)(Consisting of:)	1
3-1		Klipring	(1)
3-2		Spring	(1)
3-3		Sleeve, Detector	(1)
3-4		Bushing, Threaded Assembly	(1)
3		Spring Loaded Seal	(1)
3-4		Pin, Connector	(1)
4	*560-029-000	O-Ring Kit	1
	(Consisting of:)	560-029-360 O-Ring	(2)
		560-029-358 O-Ring	(2)
		560-029-363 O-Ring	(2)
		560-029-364 O-Ring	(2)

\*Parts in Kits not sold separately

**Model: 031-024-110**

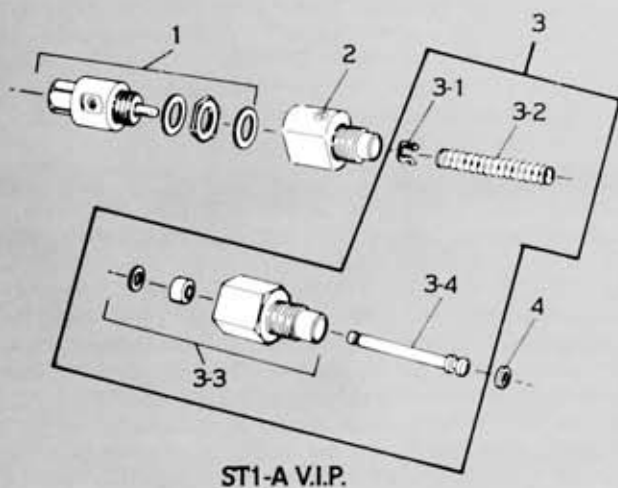

**ST1-A V.I.P.**

**Model: 031-023-110**

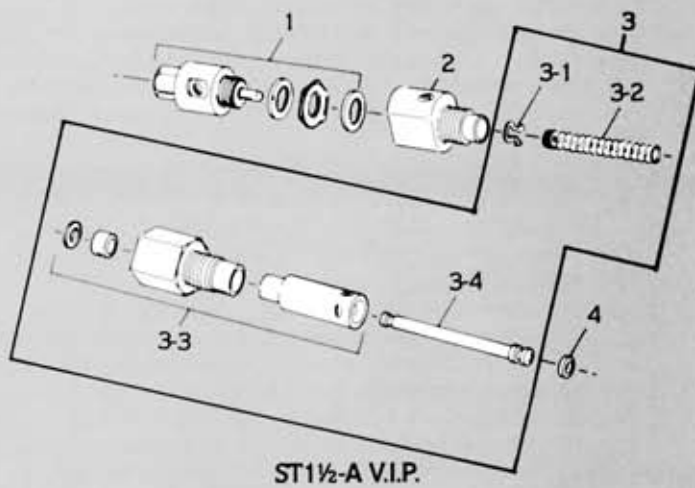

**ST1½-A V.I.P.**

**MATERIAL CODES: The Material Code Is The Last 3 Digits Of The Part Number**

- 000 ... Assembly, sub-assembly, and some purchased items
- 010 ... Cast Iron
- 015 ... Ductile Iron
- 080 ... Carbon Steel, AISI B-1112
- 100 ... Alloy 20
- 110 ... Alloy Type 316 Stainless Steel
- 112 ... Alloy "C"
- 114 ... 303 Stainless Steel
- 115 ... 302/304 Stainless Steel
- 117 ... 440-C Stainless Steel (Martensitic)
- 120 ... 416 Stainless Steel (Wrought Martensitic)
- 123 ... 410 Stainless Steel (Wrought Martensitic)
- 148 ... Hardcoat Anodized Aluminum
- 149 ... 2024-T4 Aluminum
- 150 ... 6061-T6 Aluminum
- 151 ... 6063-T6 Aluminum
- 152 ... 2024-T4 Aluminum (2023-T351)
- 154 ... Almag 35 Aluminum
- 155 or 156 ... 356-T6 Aluminum
- 157 ... Die Cast Aluminum Alloy #380
- 159 ... Anodized Aluminum
- 162 ... Brass, Yellow, Screw Machine Stock

- 165 ... Cast Bronze, BS-5-5-5
- 170 ... Bronze, Bearing Type, Oil Impregnated
- 180 ... Copper Alloy
- 310 ... PVDF Coated
- 330 ... Plated Steel
- 331 ... Chrome Plated Steel
- 332 ... Electroless Nickel Plated
- 335 ... Galvanized Steel
- 357 ... Ruppion (Urethane Rubber) Color coded: PURPLE (Injection Mold)
- 358 ... Ruppion (Urethane Rubber) Color coded: PURPLE (Some Applications) (Compression Mold)
- 360 ... Buna-N Rubber. Color coded: RED
- 363 ... Viton (Fluorel). Color coded: YELLOW
- 364 ... E.P.D.M. Rubber. Color coded: BLUE
- 365 ... Neoprene Rubber. Color coded: GREEN
- 366 ... Food Grade Nitrile. Color coded: WHITE

- 370 ... Butyl Rubber. Color coded: BROWN
- 375 ... Fluorinated Nitrile
- 405 ... Cellulose Fibre
- 408 ... Cork and Neoprene
- 425 ... Composed Fibre
- 440 ... Vegetable Fibre
- 465 ... Fibre
- 500 ... Delrin 500
- 505 ... Acrylic Resin Plastic
- 520 ... Injection Molded PVDF, Natural color, Food Grade/USDA Acceptable
- 540 ... Nylon
- 550 ... Polyethylene
- 570 ... Rulon II
- 580 ... Ryton
- 590 ... Valox
- 591 ... Nyatron G-5
- 592 ... Nyatron NSB
- 600 ... Teflon (virgin material) Tetrafluorocarbon (TFE)
- 601 ... Teflon (Bronze and moly filled)
- 602 ... Filled Teflon
- 603 ... Blue Gylon
- 604 ... Teflon, Diaphragm

Delrin, Teflon, Viton and Hytrel are registered trademarks of E.I. DuPont. Gylon is a registered trademark of Garlock, Inc. Nyatron is a registered trademark of Polymer Corporation. Rulon II is a registered trademark of Dixon Industries Corp. Ruppion and SandPIPER are registered trademarks of Warren Rupp, Inc. Ryton is a registered trademark of Phillips Chemical Company. Valox is a registered trademark of General Electric Company.

Copyright © 1992 Warren Rupp, Inc. All rights reserved.